

2461500COM Beverage Cabinet

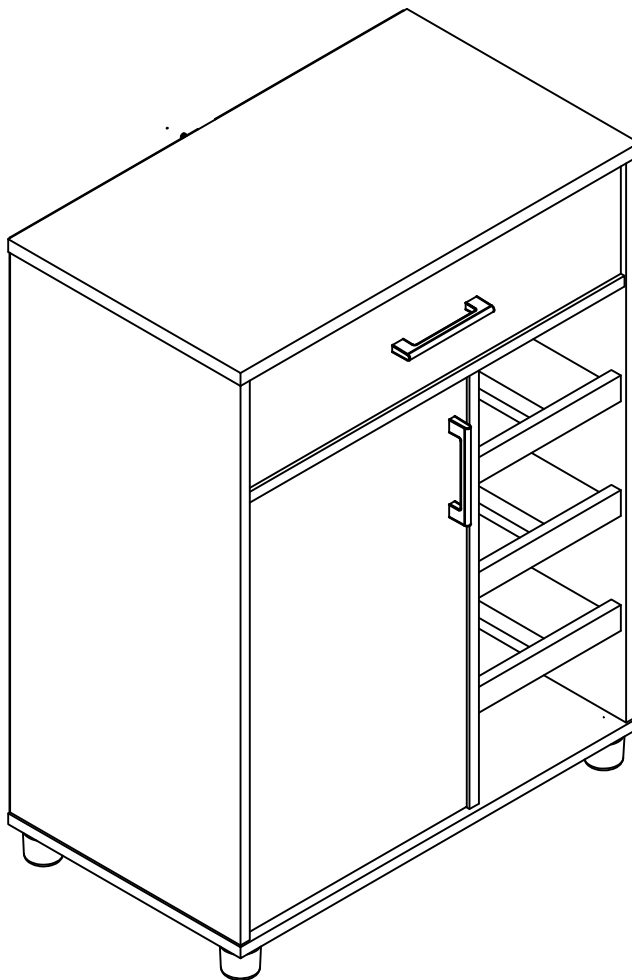

Date of Purchase ___ / ___ / ___
Lot Number:

B342461500COM0



THIS INSTRUCTION BOOKLET CONTAINS **IMPORTANT** SAFETY INFORMATION. PLEASE READ AND KEEP FOR FUTURE REFERENCE.

Secure Your Furniture

Keep your home and family safe with the wall anchor kit that is included with the product.

Serious or fatal crushing injuries can occur from tipping furniture.

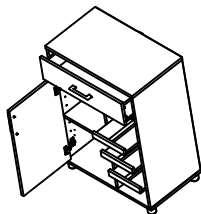

WARNING: Manufacturer assumes no liability for improper installation or excessive loads placed on screws or bracket. This wall anchor is not a substitute for proper adult supervision.

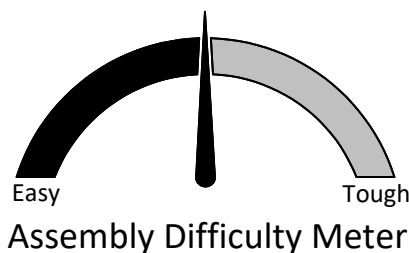

For the latest information on SystemBuild products follow us at Ameriwood Home



Contact Us!

Do NOT return this product!

Contact our friendly customer service team first for help.

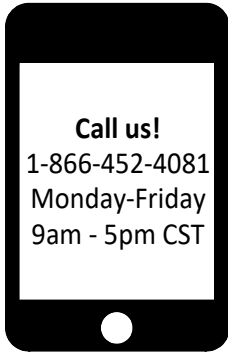

Visit systembuild.com to view the limited warranty valid in the U.S. and Canada.

Assembly Tips



Helpful Hints

PEOPLE NEEDED FOR ASSEMBLY: 1-2

- Open your item in the area you plan to keep it to avoid excessive heavy lifting.
- Identify, sort and count the parts before attempting assembly.
- Compression dowels are lightly tapped in with a hammer.
- Slides are labeled with a **R** (right) and **L** (left) for proper placement.
- Make sure to always face the point on the top of the Cam Lock towards the outer edge.
- Use all the nails provided for the back panel and spread them out equally.
- Back panel must be used to make sure your unit is sturdy.
- Do NOT use harsh chemicals or abrasive cleaners on this item.
- Never push, pull, or drag your furniture.



Before You Start

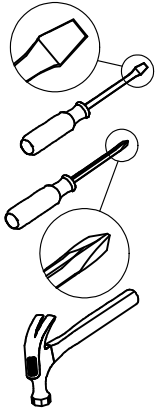
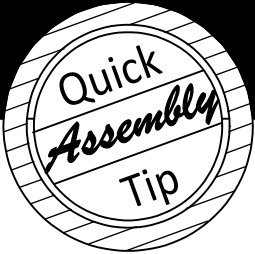

- ✓ Read through each step carefully and follow the proper order
- ✓ Separate and count all your parts and hardware
Parts are labeled on the surface or edge of the part
- ✓ Give yourself enough room for the assembly process
- ✓ Have the following tools: Flat Head Screwdriver, #2 Phillips Head Screwdriver and Hammer
- ✓ Caution: If using a power drill or power screwdriver for screwing, please be aware to slow down and stop when screw is tight. Failure to do so may result in stripping the screw.

Cam Lock Fastening System

This Cam Lock Fastening System will be used throughout the assembly process.

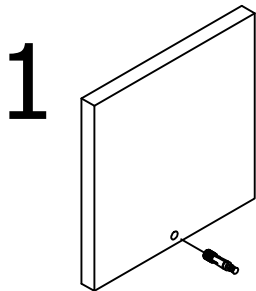

1 Press CAM BOLT into hole.

2

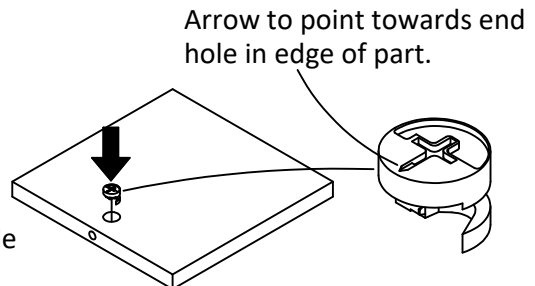

End hole

Press CAM LOCK into hole.

3

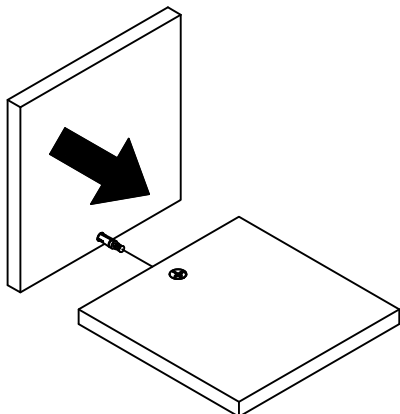

Press parts together so CAM BOLT inserts into edge hole.

4

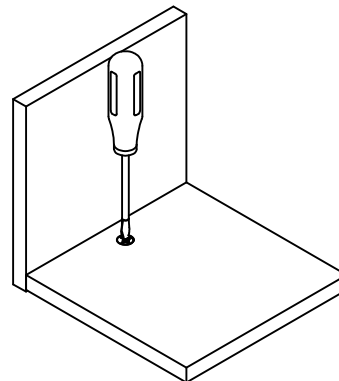

Using a screwdriver, turn the CAM LOCK clockwise to lock the CAM LOCK and CAM BOLT into their holes and fastening parts together.

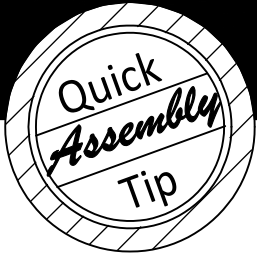

Before You Start

Please Note:
You may need to lightly tap the wood dowels into the holes during your assembly process.

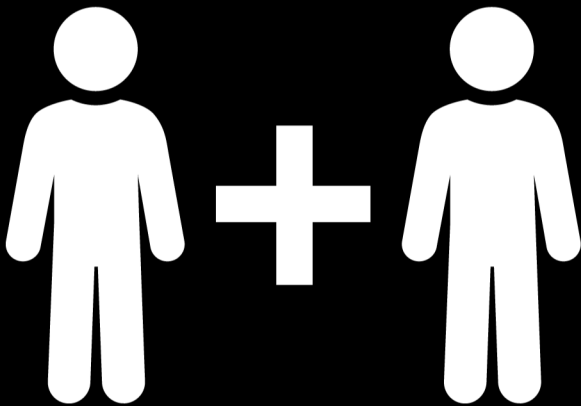
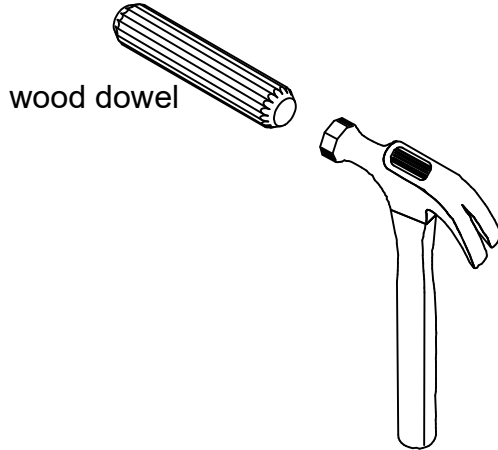

2 PEOPLE NEEDED FOR ASSEMBLY

**2 PERSONAS NECESITADAS
PARA LA ASAMBLEA**

**2 PERSONNES NÉCESSAIRES
POUR L'ASSEMBLAGE**

CAUTION: Failure to use 2 people for assembly could result in unit damage or personal injury.

PRECAUCIÓN: Si no se utilizan 2 personas para el ensamblaje, se pueden producir daños en la unidad o lesiones personales.

ATTENTION: Échec d'utiliser 2 personnes pour l'assemblage peut causer du dommage au meuble ou causer des blessures.

Board Identification

Not actual size

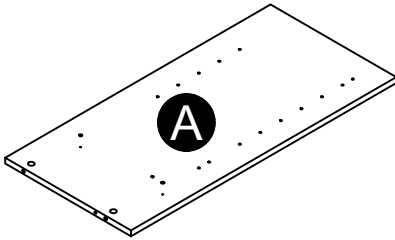

Left Panel
32461015010

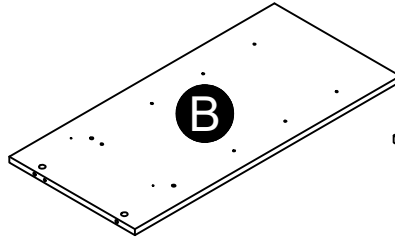

Right Panel
32461015020

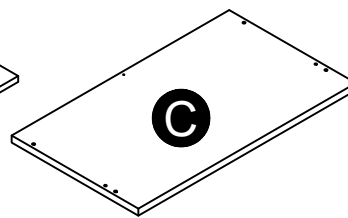

Top
32461320030

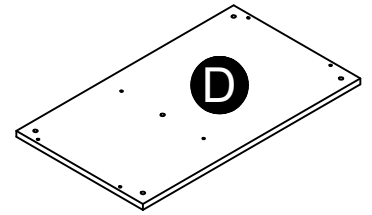

Bottom
32461320040

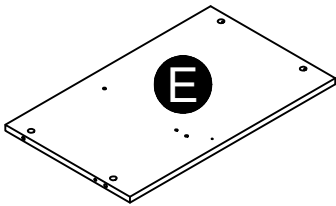

Fixed Shelf
32461015050

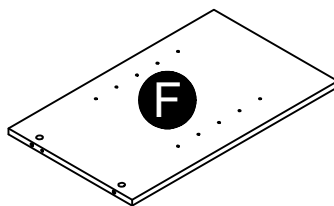

Partition
32461015060

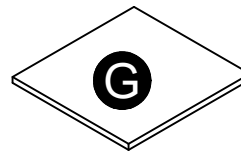

Adjustable Shelf
32461015070

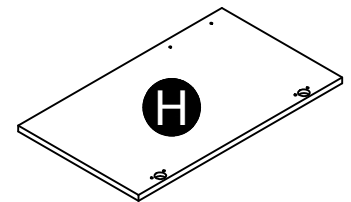

Door
32461015080

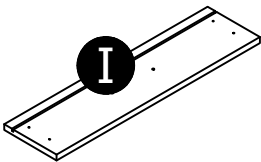

Drawer Front
32461015090

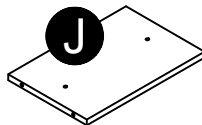

Beverage Shelf
32461015100

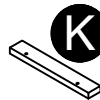

Beverage Shelf Rail
32461015110

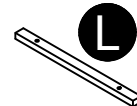

Beverage Shelf Divider
32461015120



Drawer Side (2)
39993120346200C

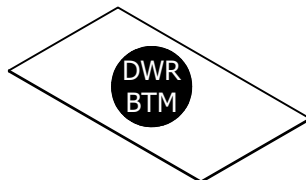

Drawer Bottom
39993340059910D



Drawer Back
39993120058850B

This piece is paperboard construction. It is not made from wood, but is required for the assembly of your unit.

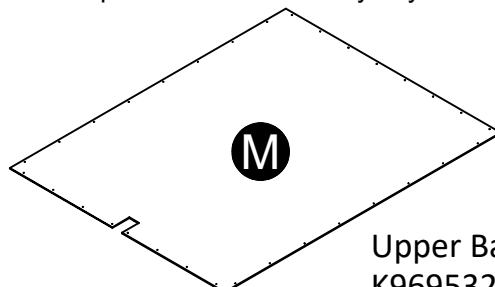

Upper Back Panel
K969532000

Board Identification

Not actual size

This piece is paperboard construction.
It is not made from wood, but is
required for the assembly of your unit.

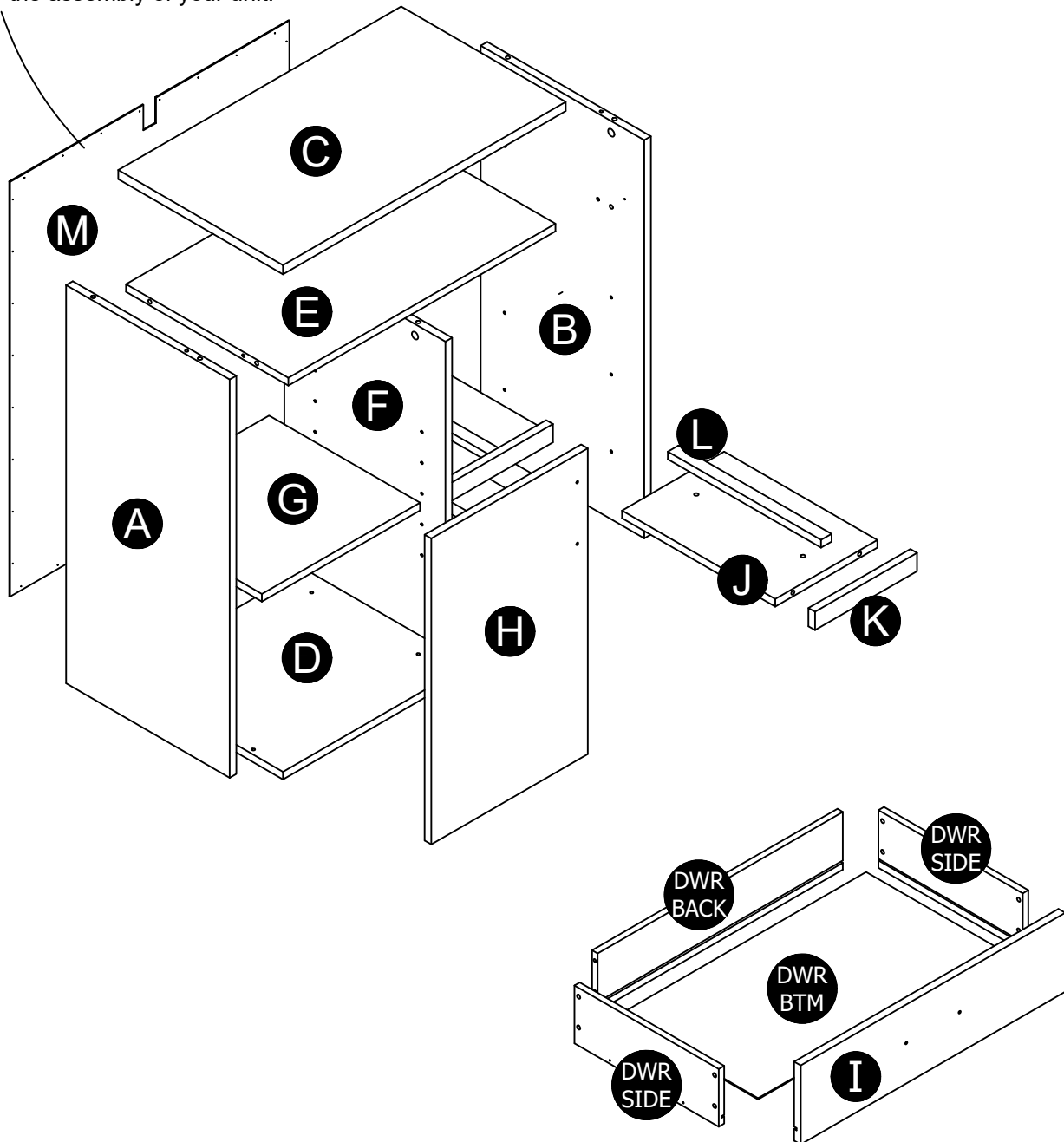

Part List

Actual Size

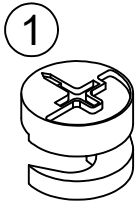

(x10)
#A22700
cam lock

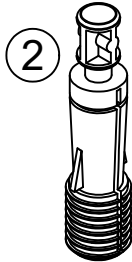

(x10)
#A22710
cam bolt



(x5)
#A21670
wood dowel

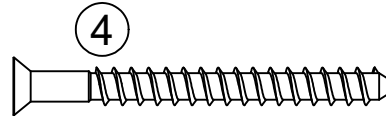

(x6)
#A23030
confirmat

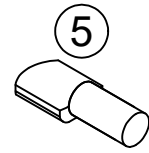

(x16)
#A80250
shelf support

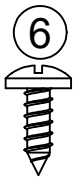

(x8)
#A12120
7/16" screw



(x8)
#A11080
7/16" screw

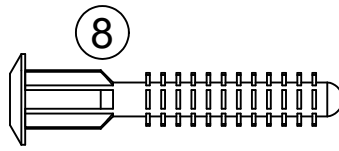

(x4)
#A21970
drive fastener



(x1)
#A11170
5/8" screw

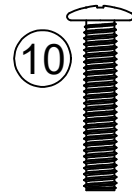

(x4)
#A17400
7/8" bolt

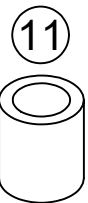

(x1)
#A89020
bumper



(x32)
#A21110
nail

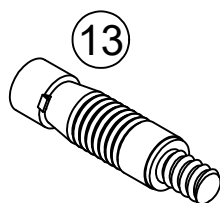

(x6)
#A21960
hidden fastener

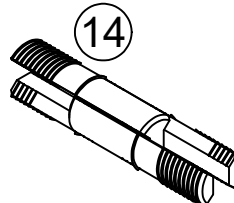

(x6)
#A21980
hidden face connector

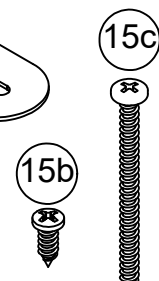
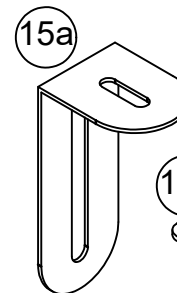

(x1)
#A84050
safety bracket kit

Part List

Not Actual Size

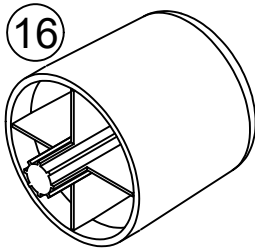

(x5)
#A43105
foot

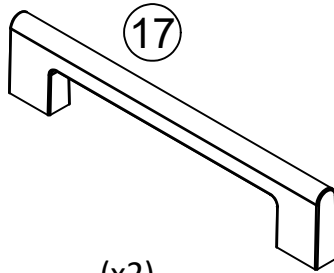

(x2)
#A50415
handle

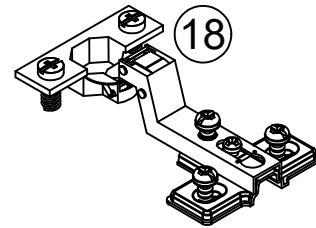

(x4)
#A65640
hinge

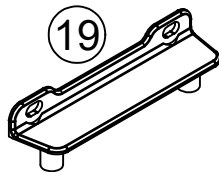

(x2)
#A54510
drawer bracket

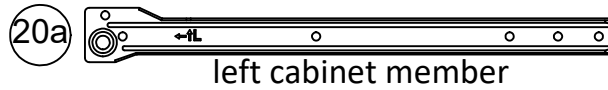

left cabinet member

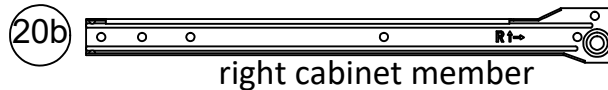

right cabinet member

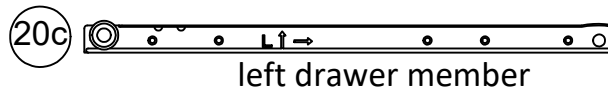

left drawer member

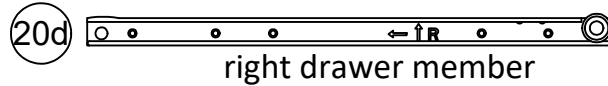

right drawer member

(x1)
#A56760
drawer slide kit

STEP 1

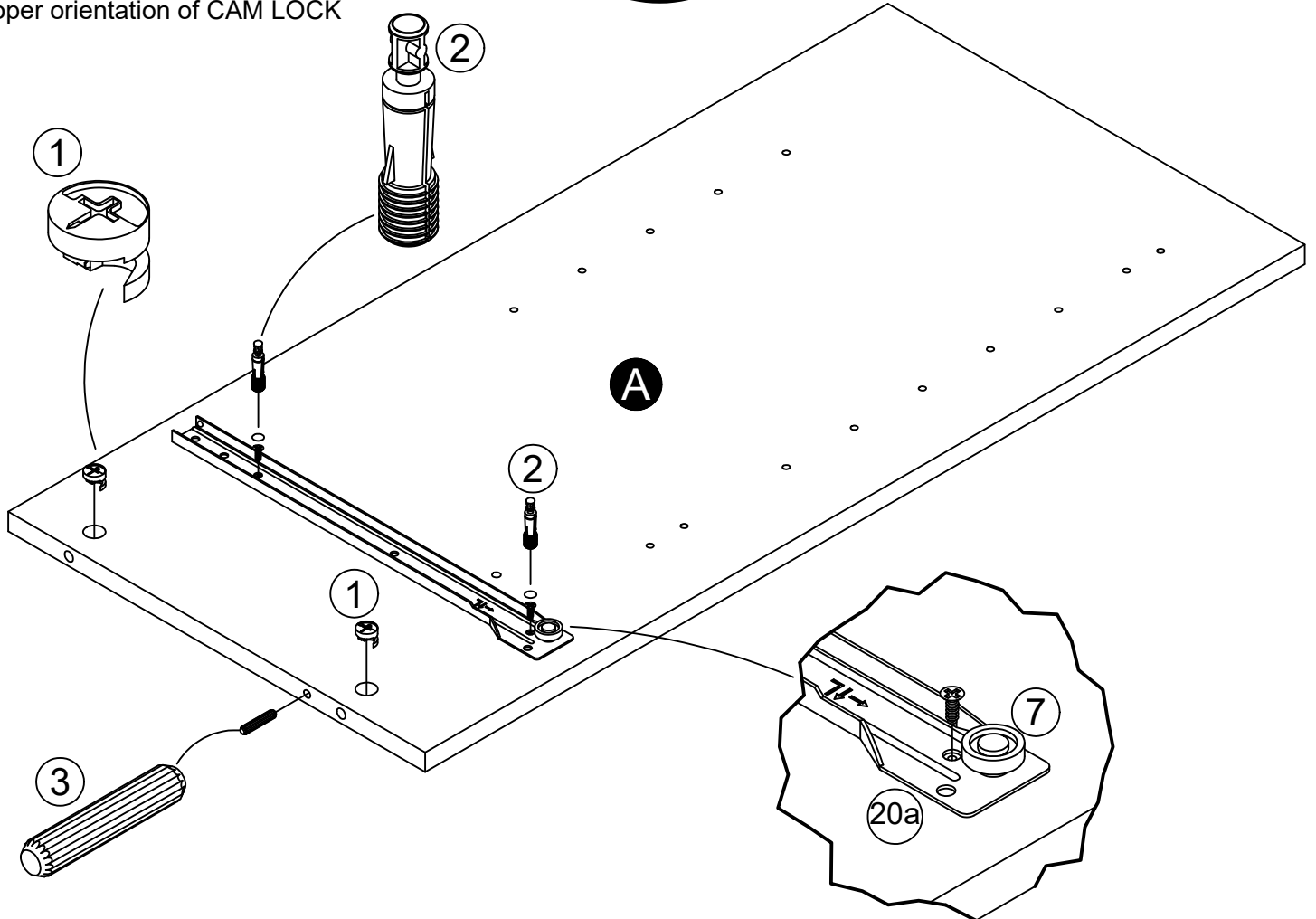
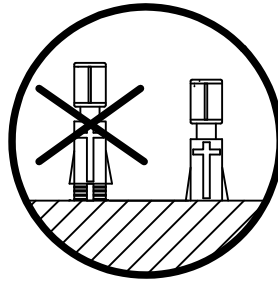
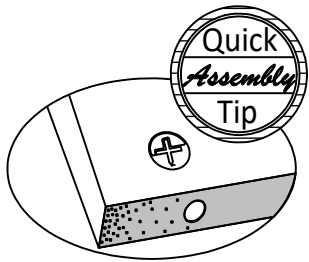
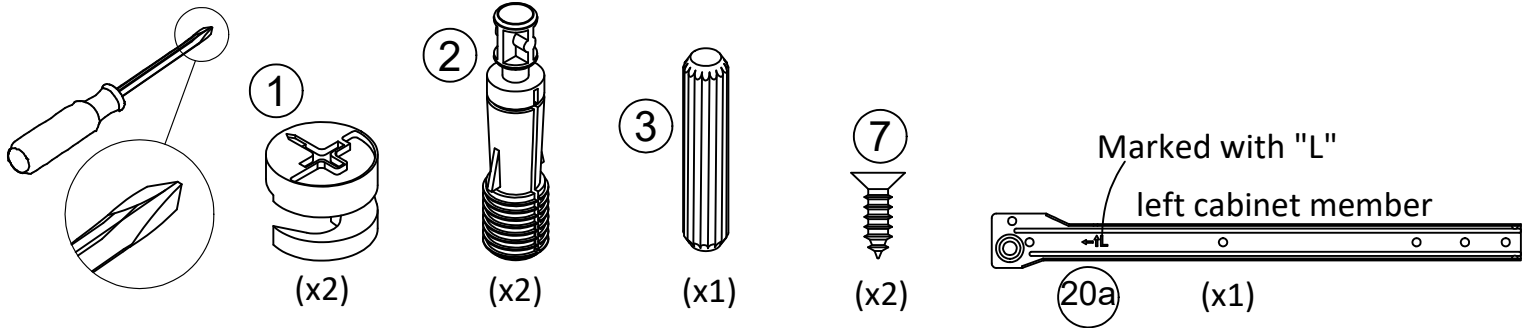

STEP 2

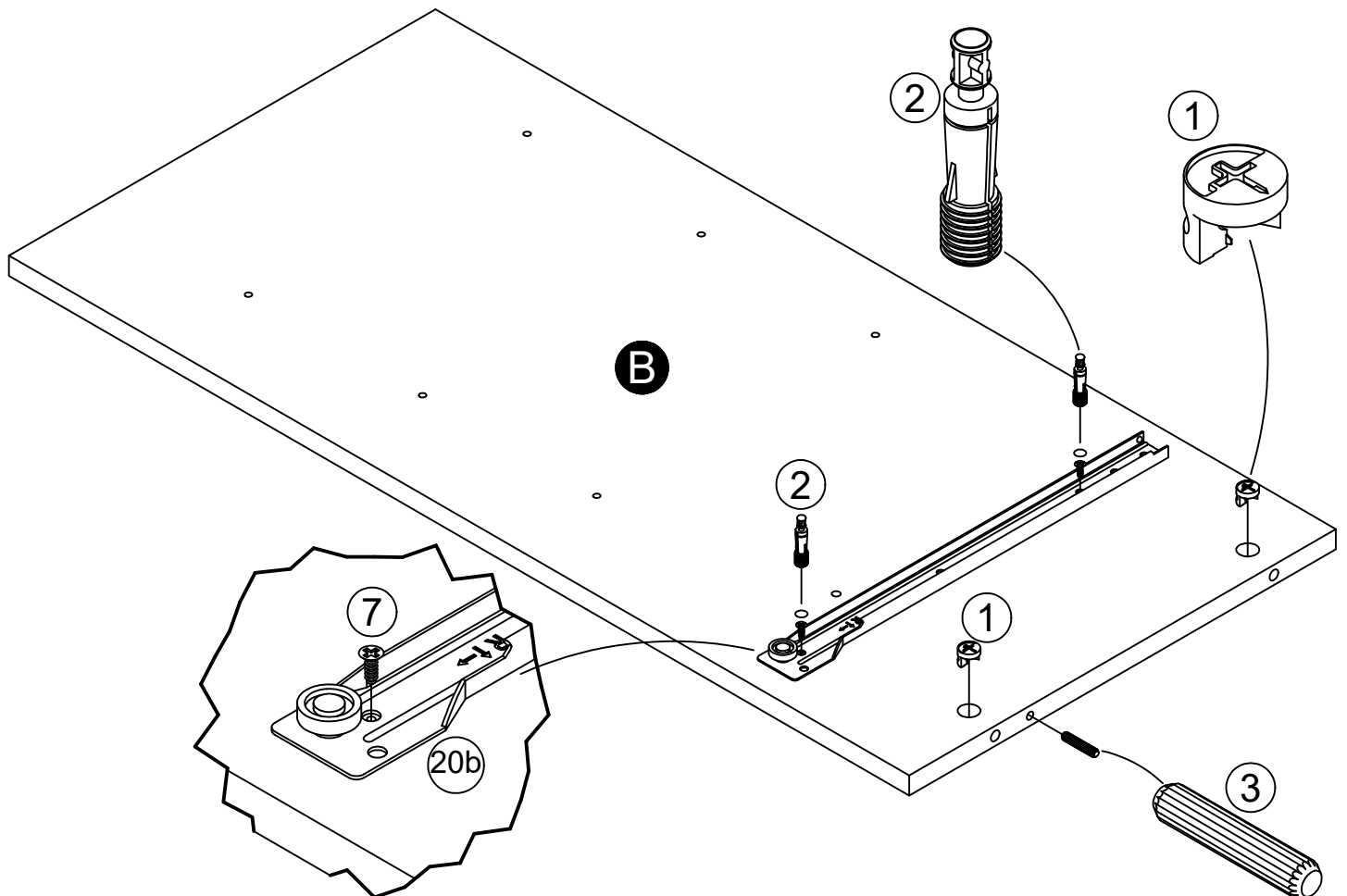
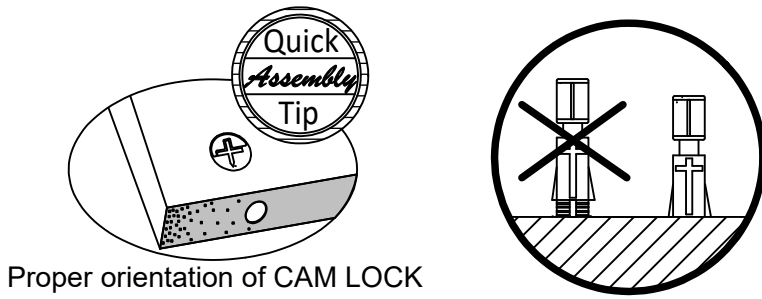
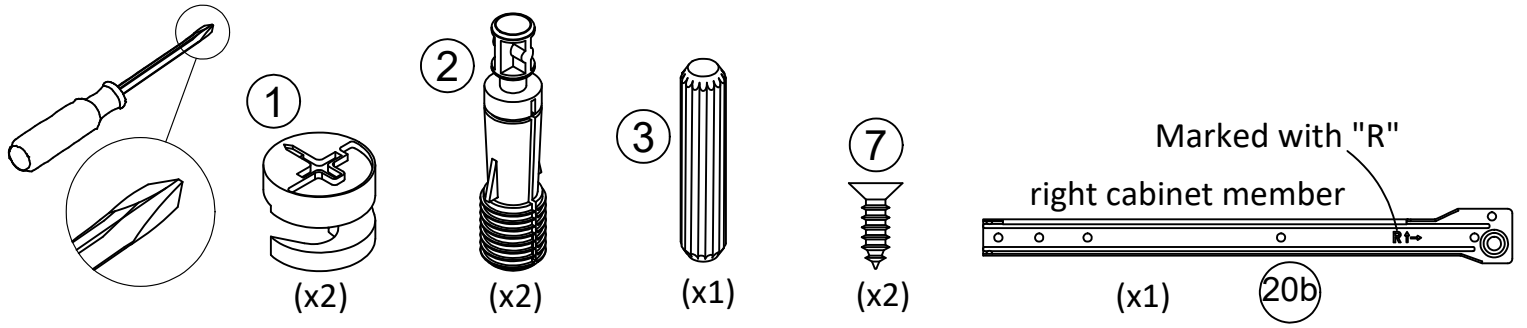

STEP 3

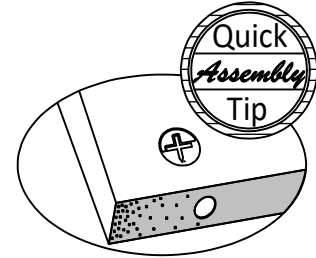
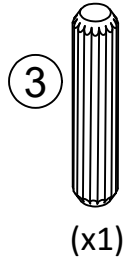
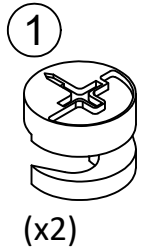

Proper orientation of CAM LOCK

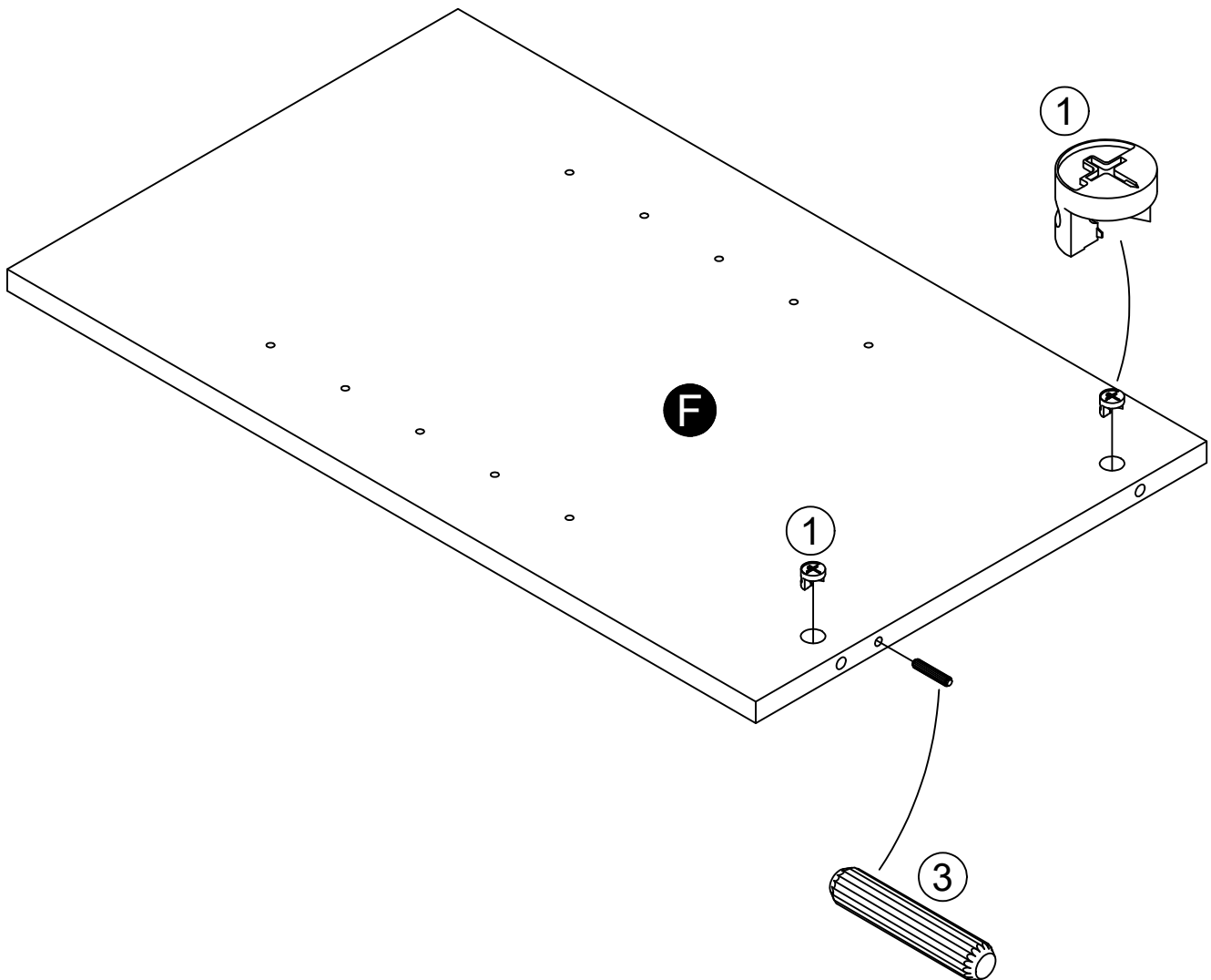

STEP 4

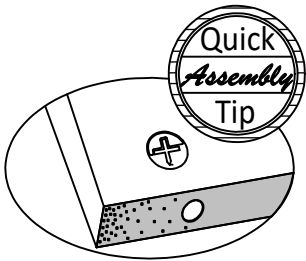
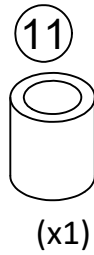
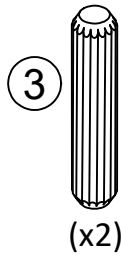
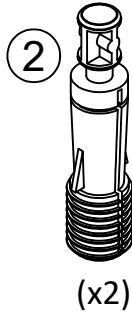
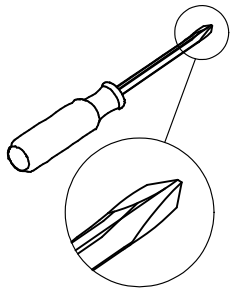

Proper orientation of CAM LOCK

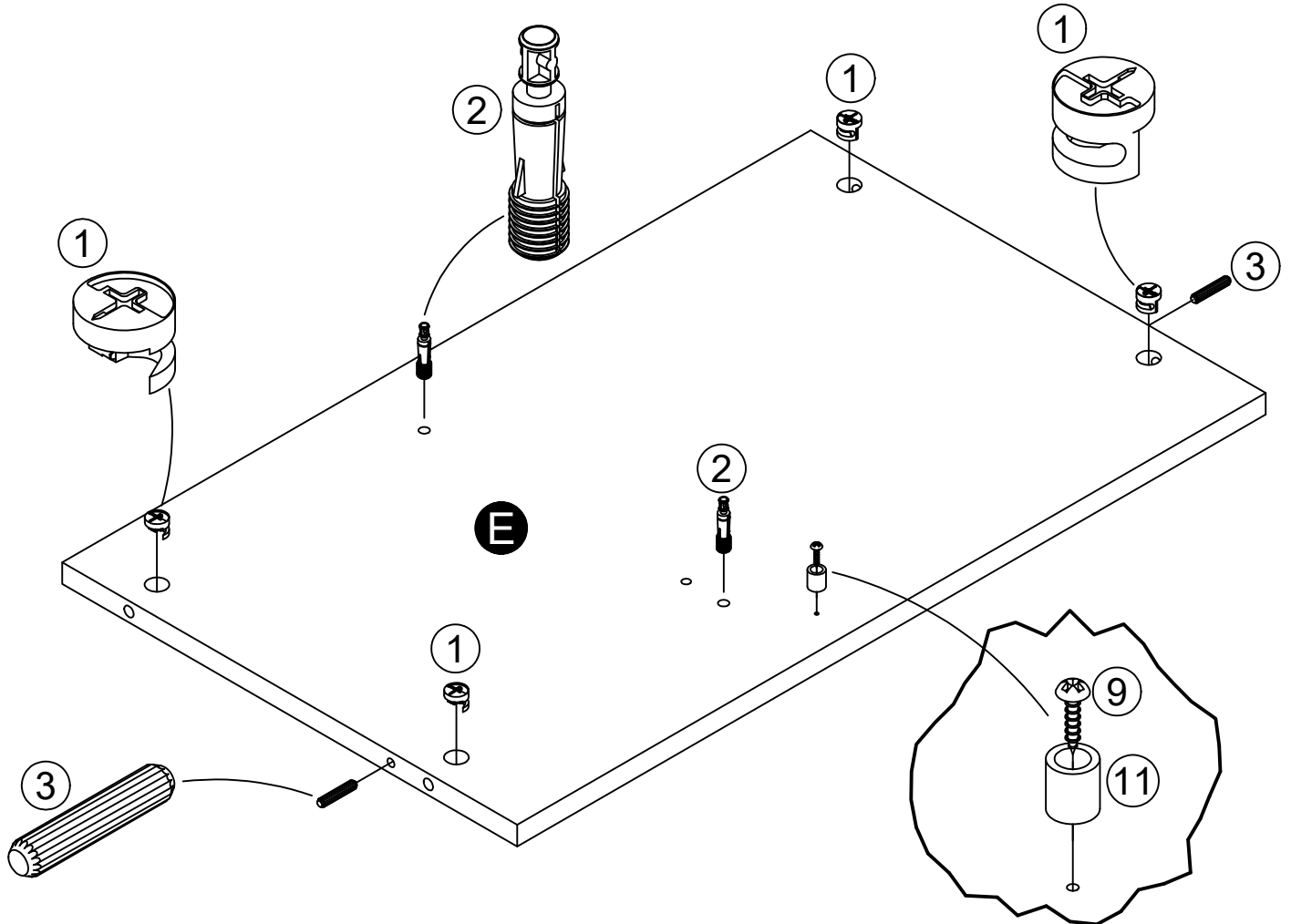
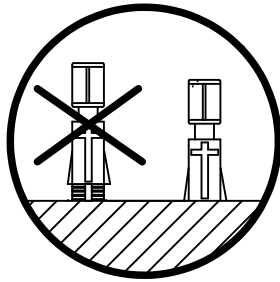

STEP 5

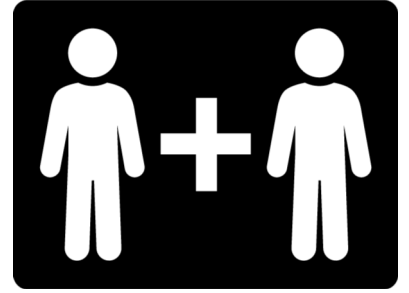
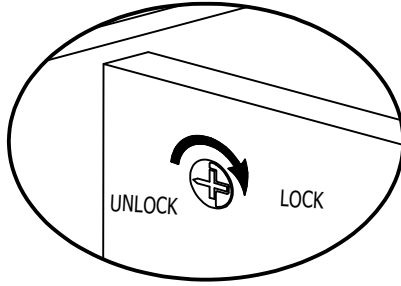
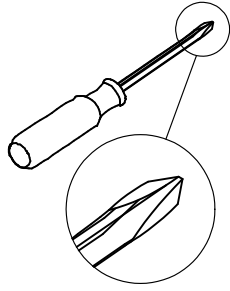

Finished edges facing up

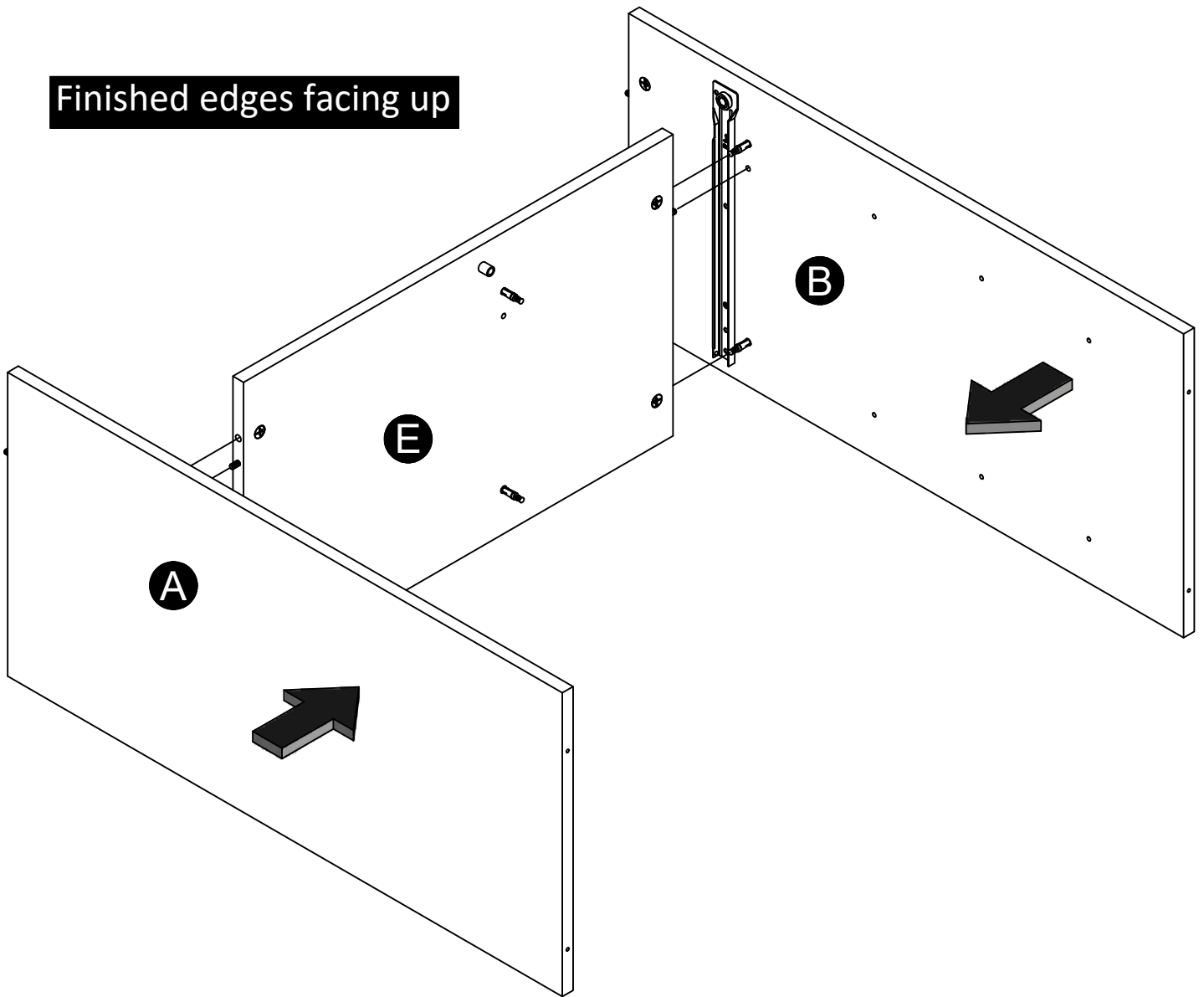

STEP 6

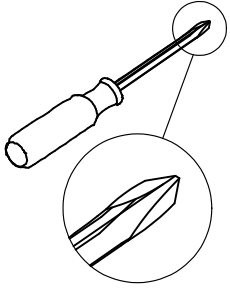

Finished edges facing up

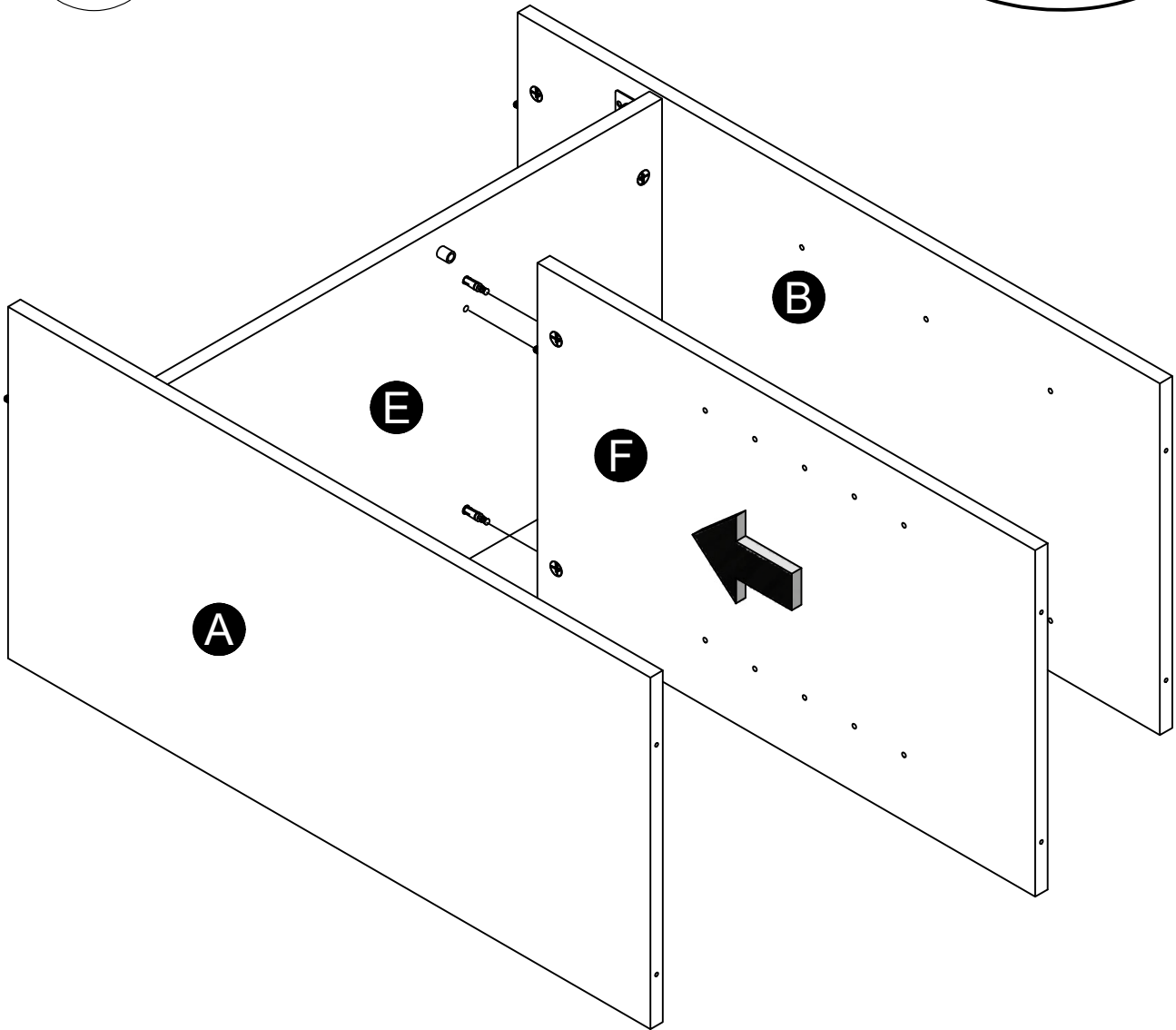
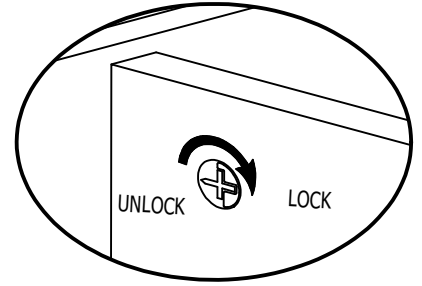

STEP 7

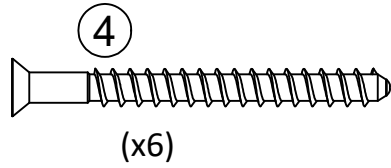
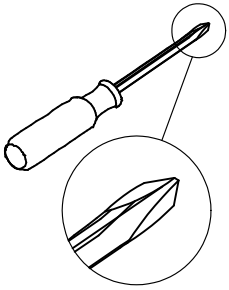

Finished edges facing up

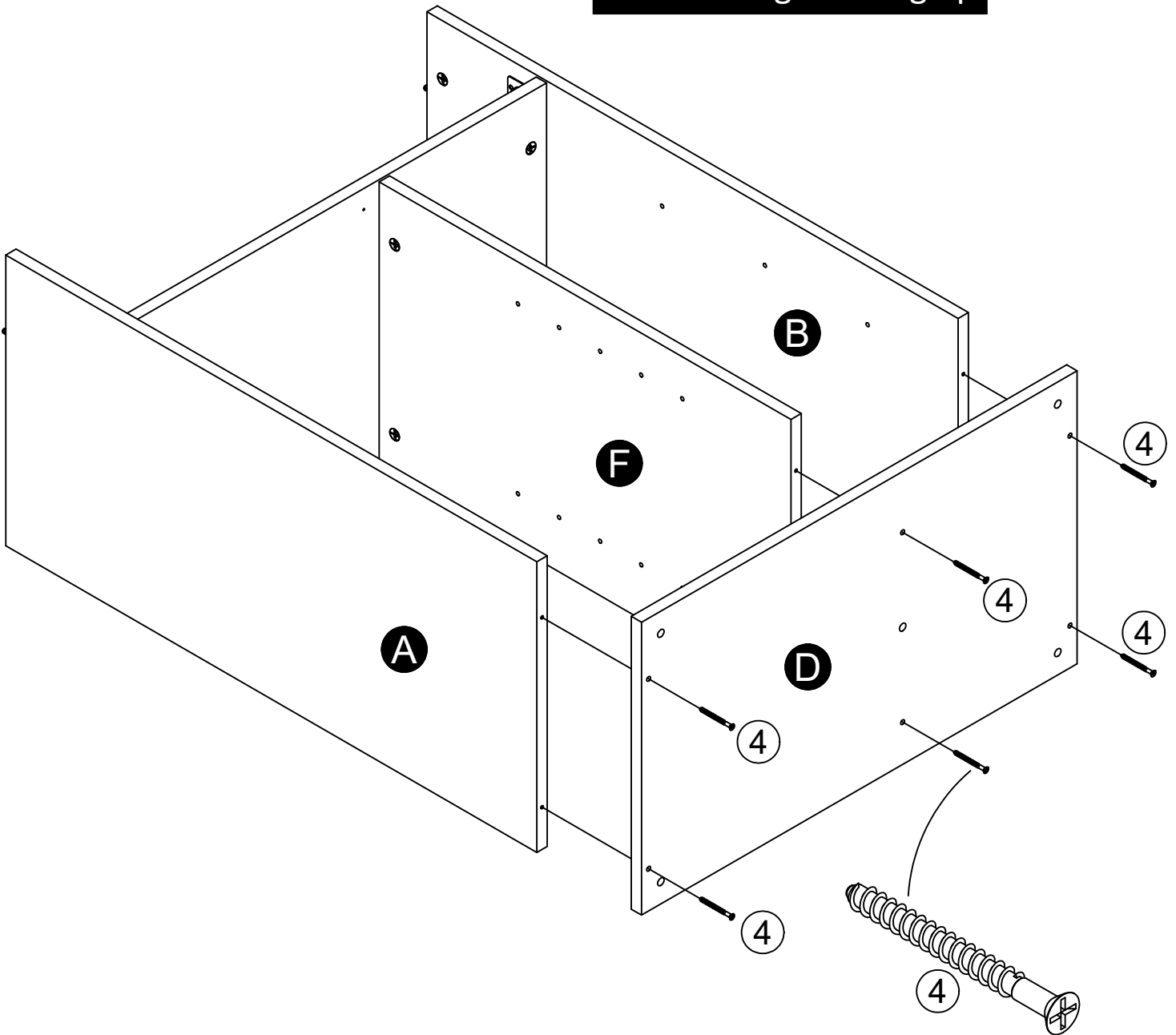

STEP 8

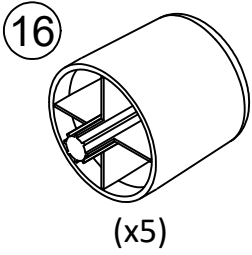

You may need to tap lightly with a hammer to fully seat.

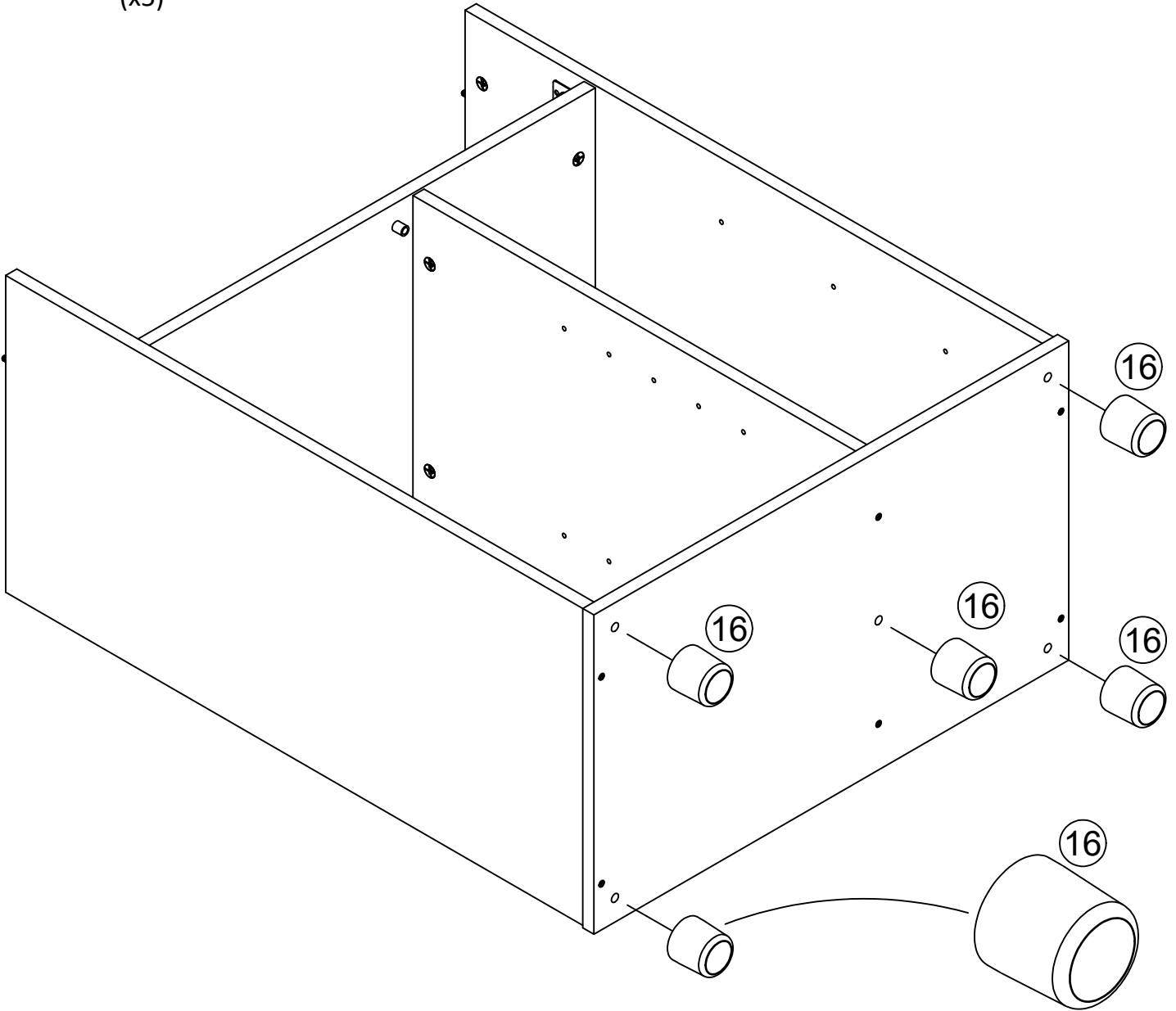

STEP 9

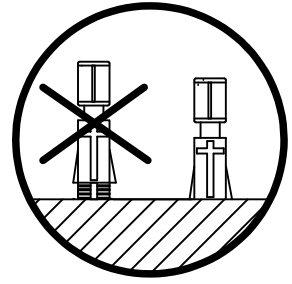
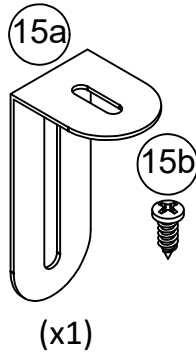
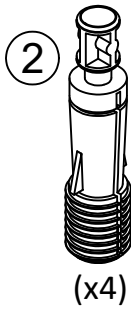
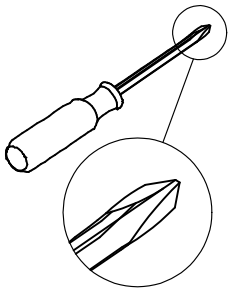

Do not fully tighten screw.

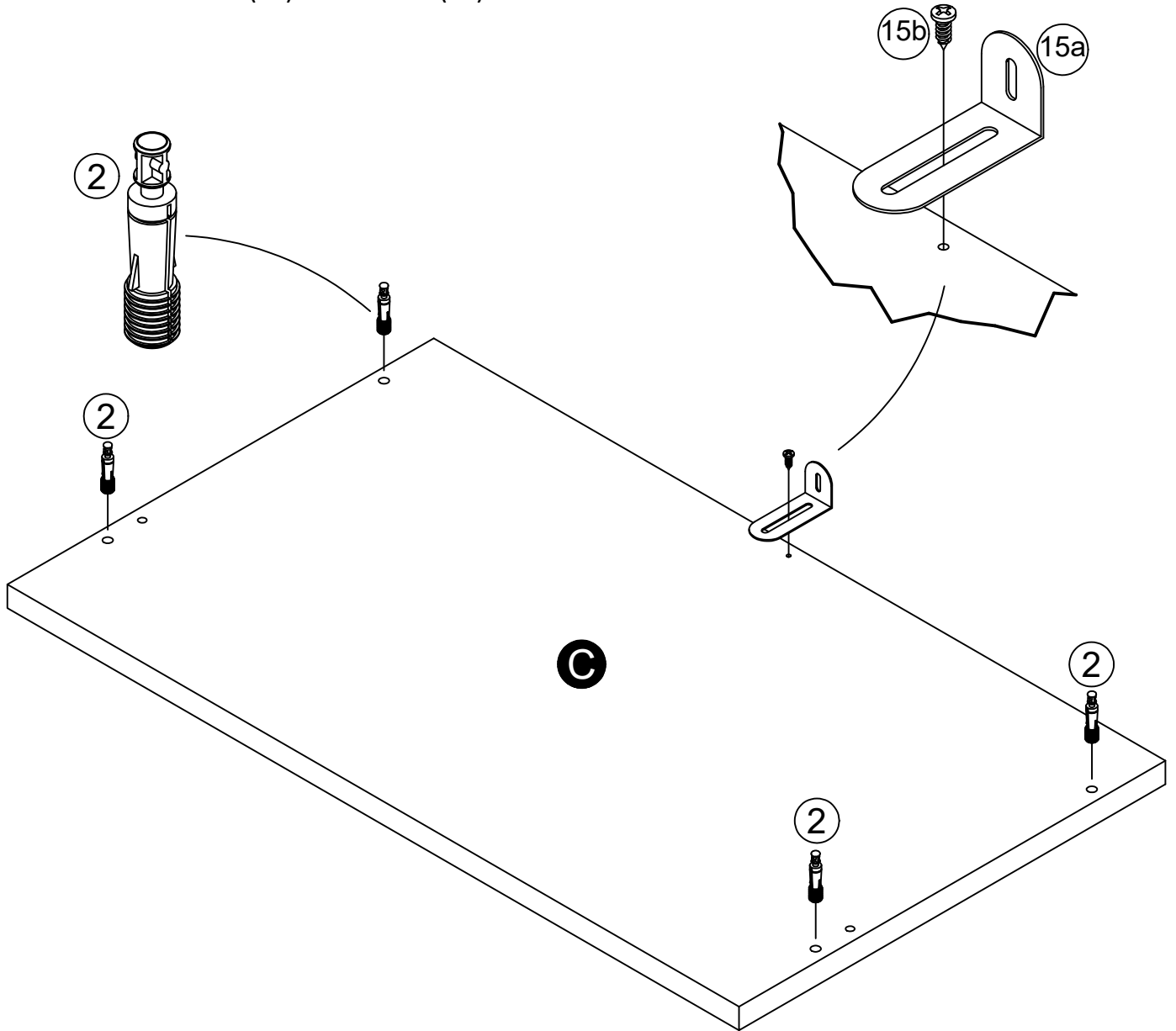

STEP 10

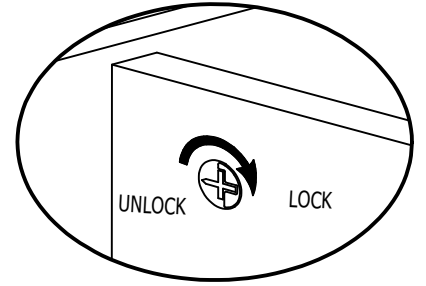
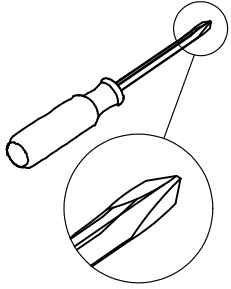

Finished edges facing up

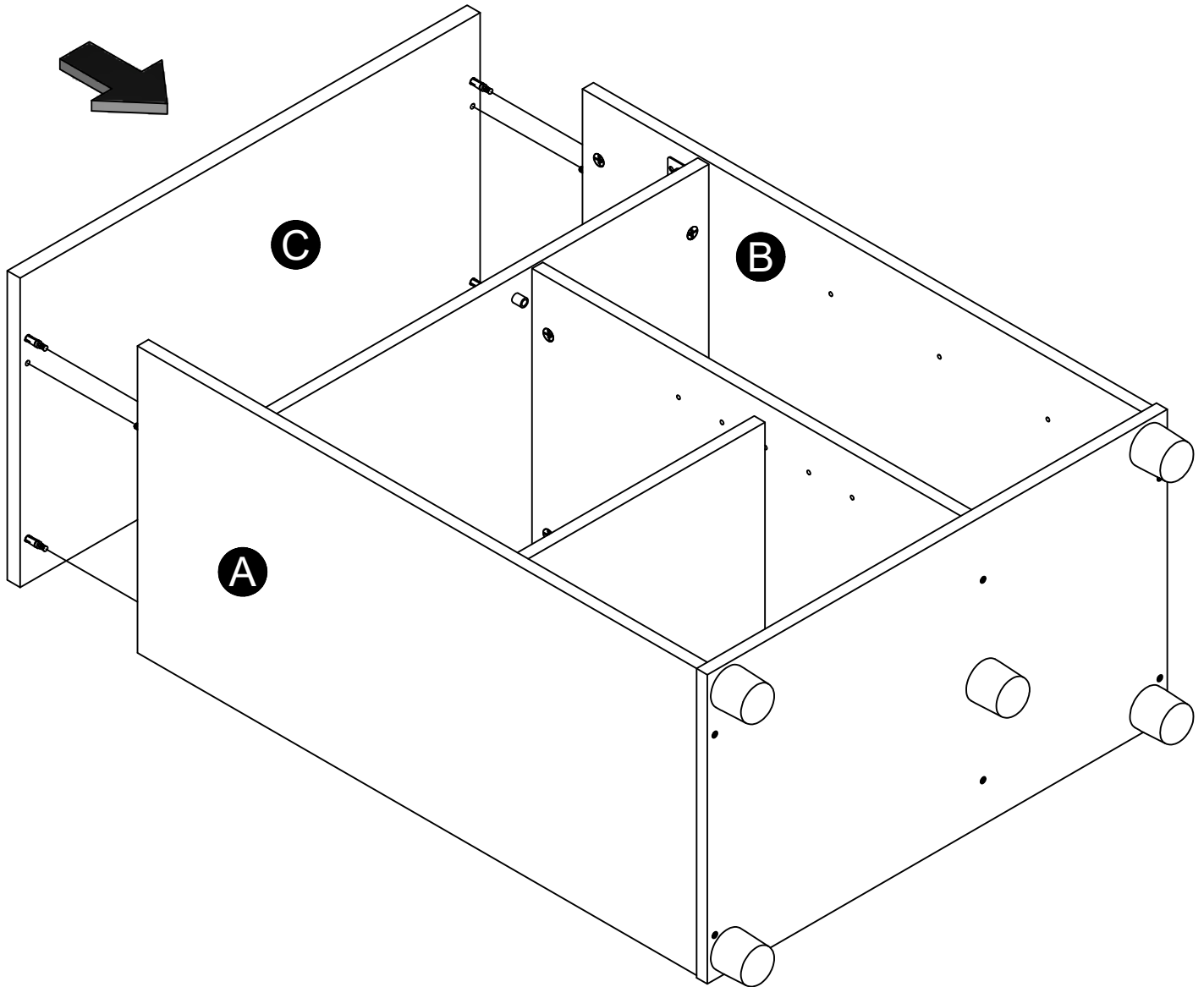

STEP 11

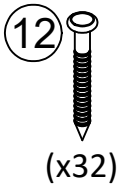
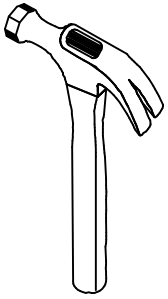

IMPORTANT! THE BACK PANEL IS A STRUCTURAL PART OF THIS UNIT AND MUST BE INSTALLED PROPERLY.

Carefully turn the cabinet over on it's front side. Position back panel as shown. Align squarely with outer edges. Flush bottom edge of back panel with bottom edge of bottom and nail straight into back edges of left panel, right panel, top and bottom.

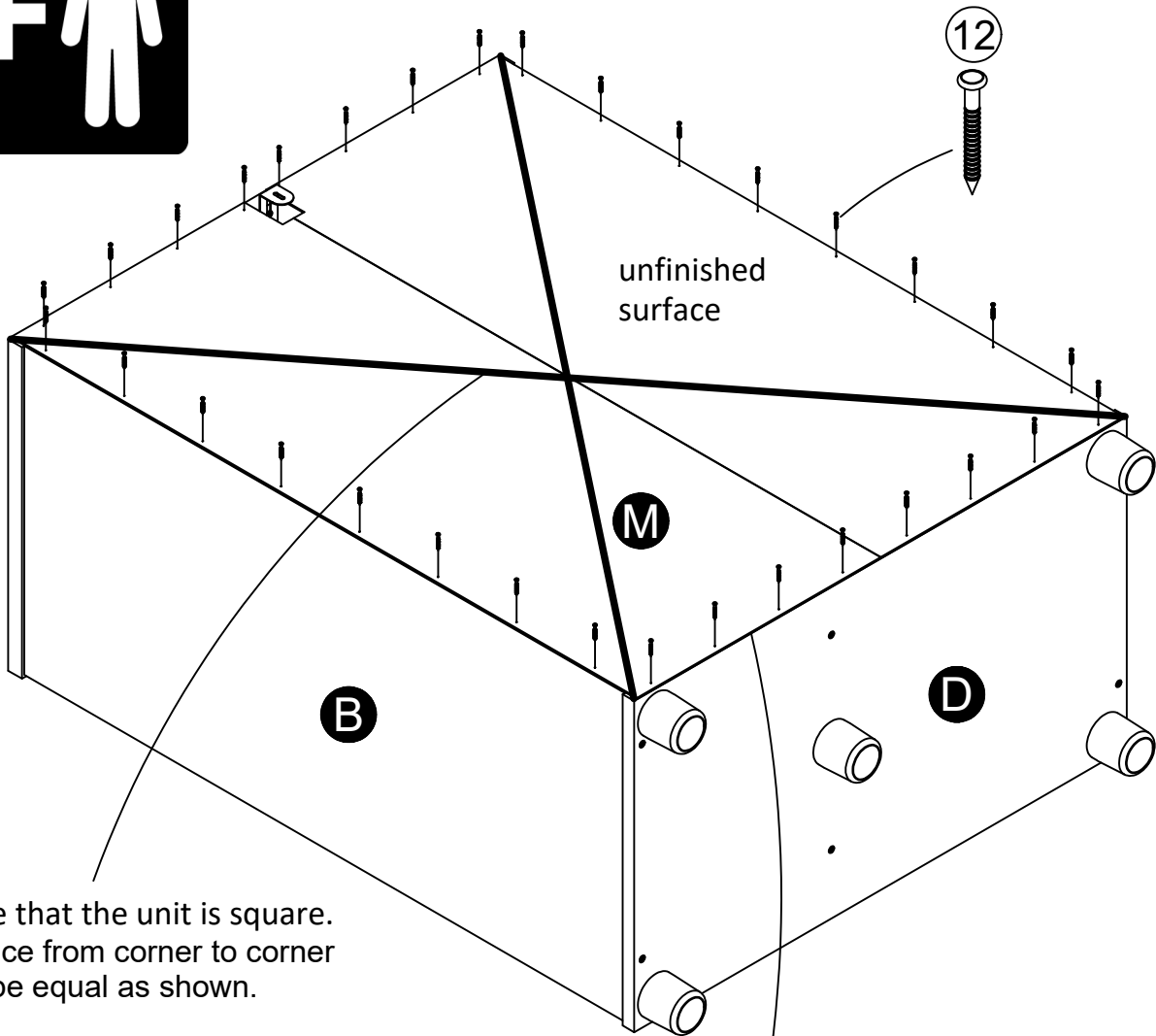
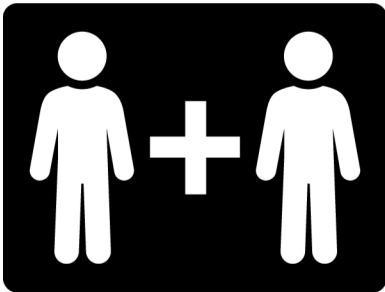

Assure that the unit is square. Distance from corner to corner must be equal as shown.

Flush the bottom edge of the Lower Back Panel with the bottom edge of Bottom (D).

STEP 12

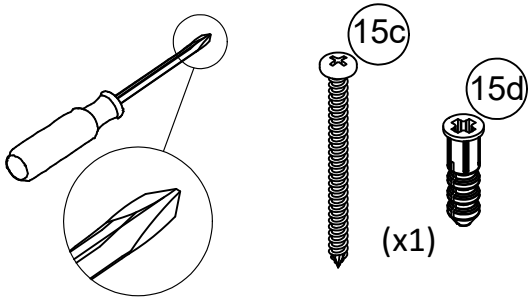

For Masonry, Concrete, or other wall materials:

Consult your local hardware store for appropriate anchors to securely attach the safety bracket.

IMPORTANT: THIS UNIT MUST BE SECURE TO THE WALL TO HELP PREVENT TIPOVER. FOLLOW THESE INSTRUCTIONS TO INSTALL THE ANTI-TIPPING SAFETY BRACKET PROVIDED WITH THIS PRODUCT.

WARNING

Serious or fatal crushing injuries can occur from furniture tipover.

To prevent tipover:

- * Install tipover restraint provided
- * place heaviest items in the lowest drawers
- * Unless specifically designed to accommodate, do not set TVs or other heavy objects on the top of this product
- * Never allow children to climb or hang on drawers, door, or shelves
- * Never open more than one drawer at a time

Use of tipover restraints may only reduce, but not eliminate the risk of tipover

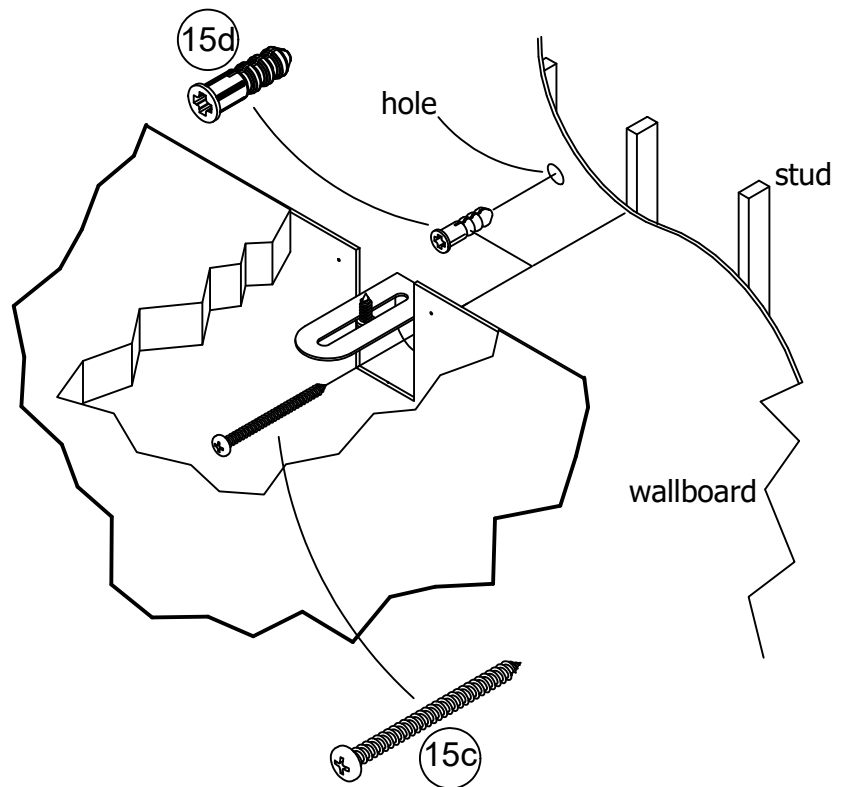

OPTION 1: Attachment into a wall stud (preferred method)

Using a stud finder, locate a stud in the wall. Place your unit against the wall, with the safety bracket aligned in this location. To make driving the screw easier, you can drill a 1/8" diameter pilot hole (3mm) through the safety bracket into the stud. Drive the screw through the safety bracket into the wall stud. Tighten the screw that was not fully tightened in step 9.

OPTION 2: Attachment into drywall

Locate your unit where desired against a wall and mark the wall through the safety bracket, then move your unit aside. Drill a 3/16" diameter hole (5mm) into the wallboard. Tap the wall anchor into the hole until it is flush. Move your unit into location and fasten the wall bracket to the wall anchor with the screw. Tighten the screw that was not fully tightened in step 9.

STEP 13

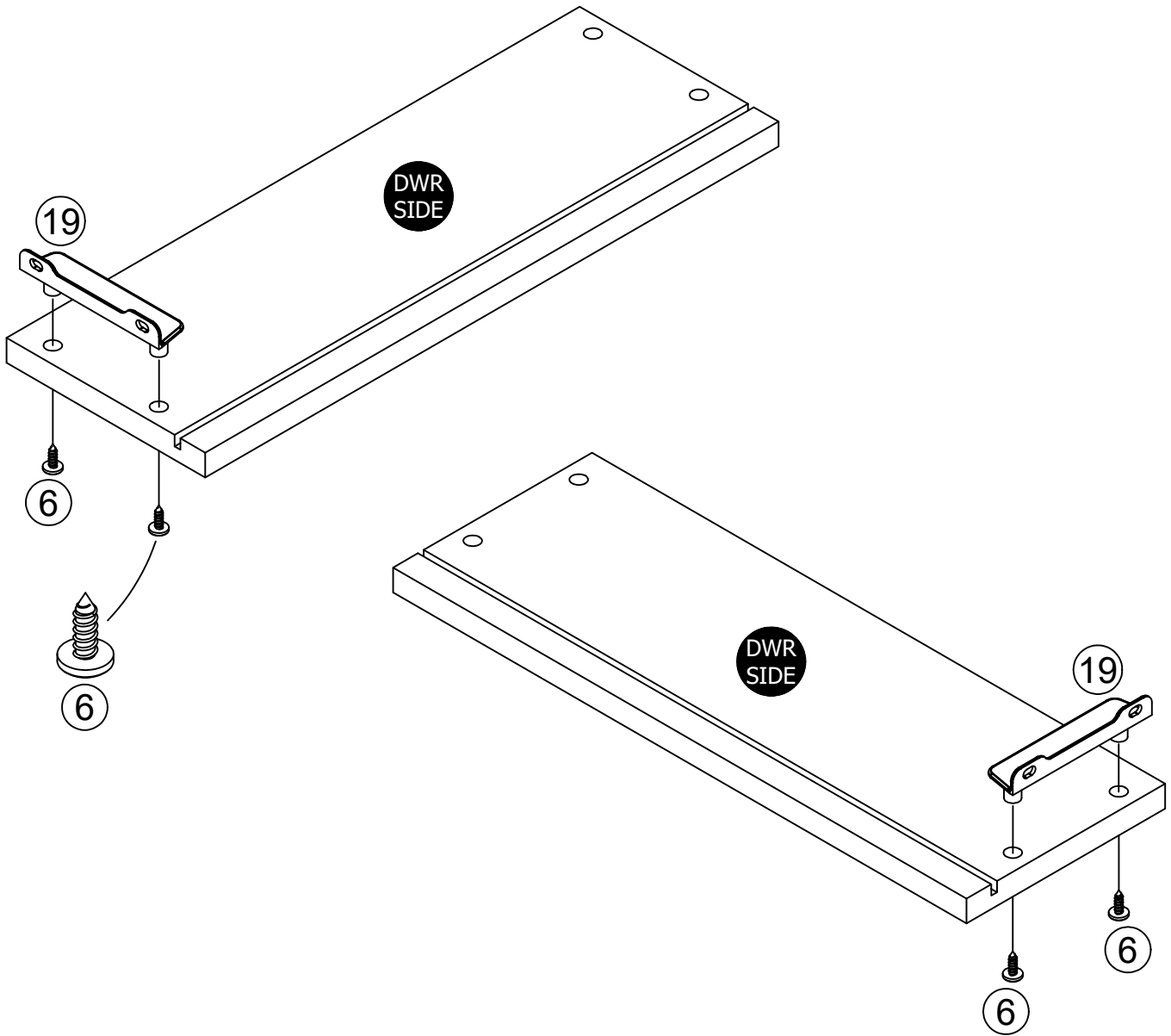
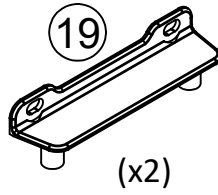
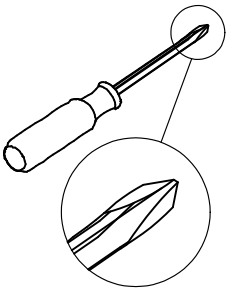

STEP 14

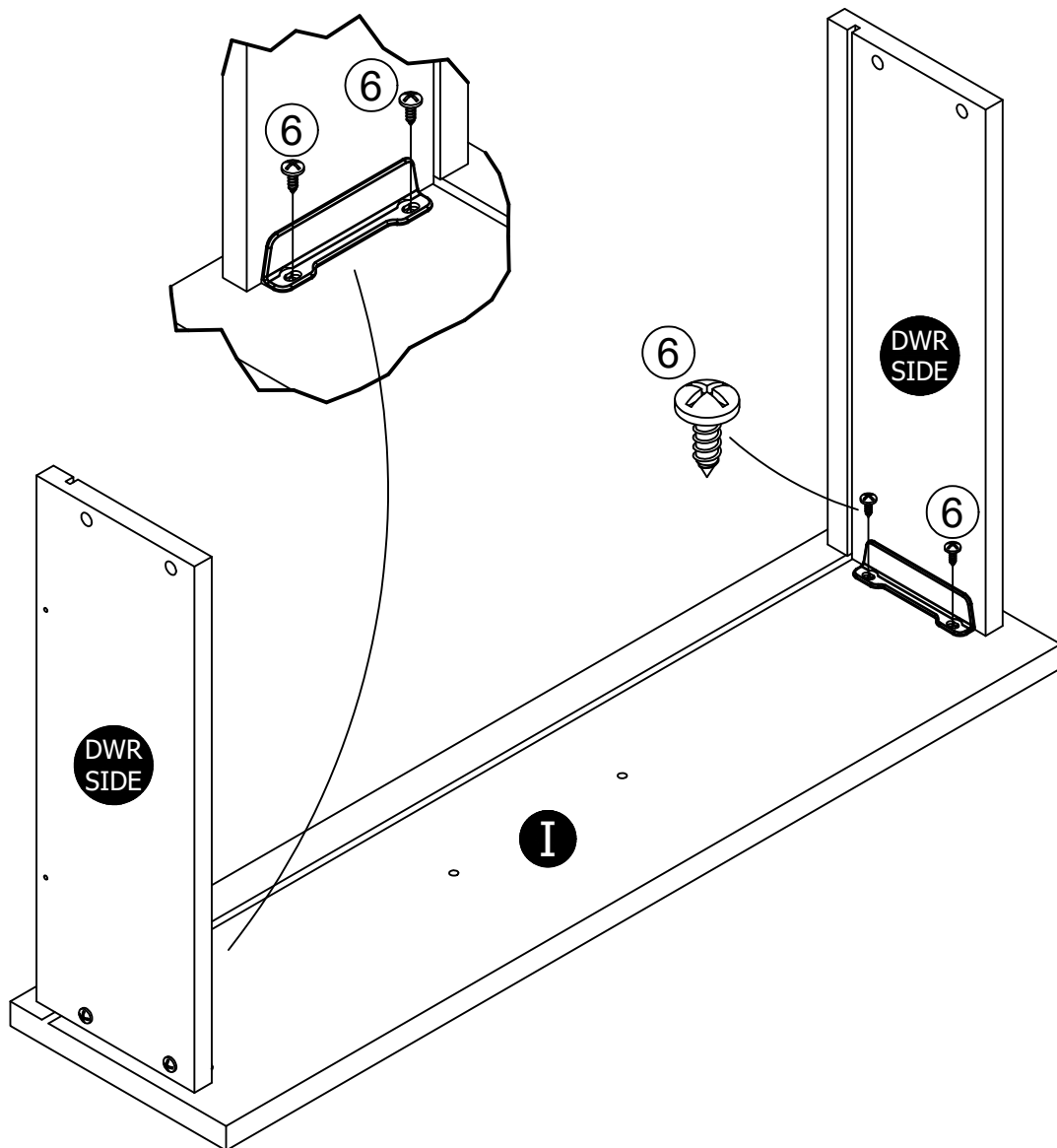
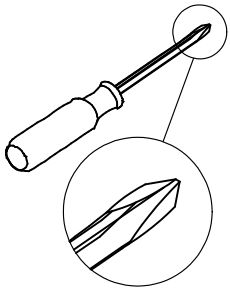

STEP 15

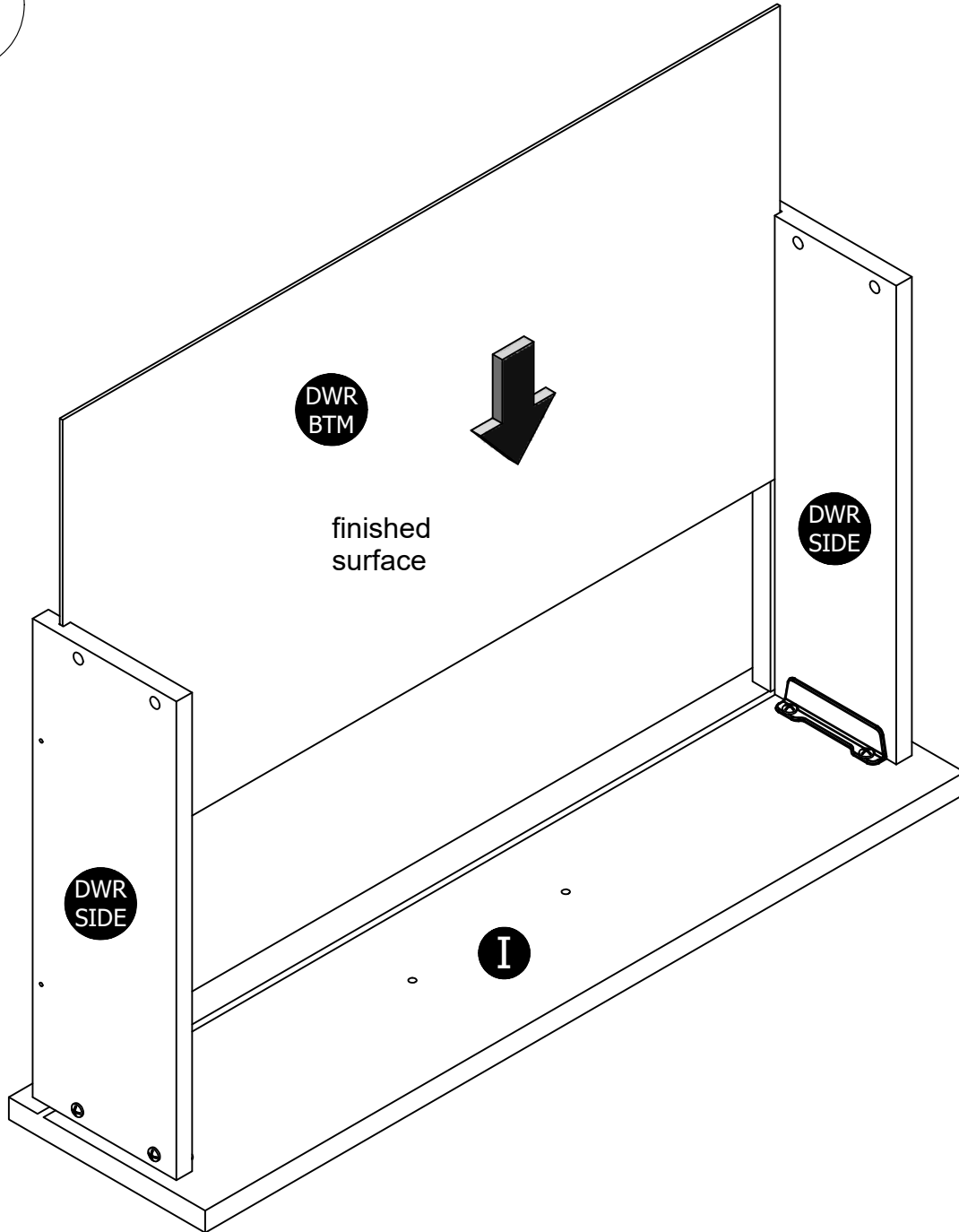
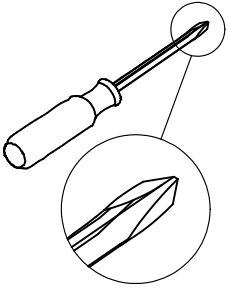

STEP 16

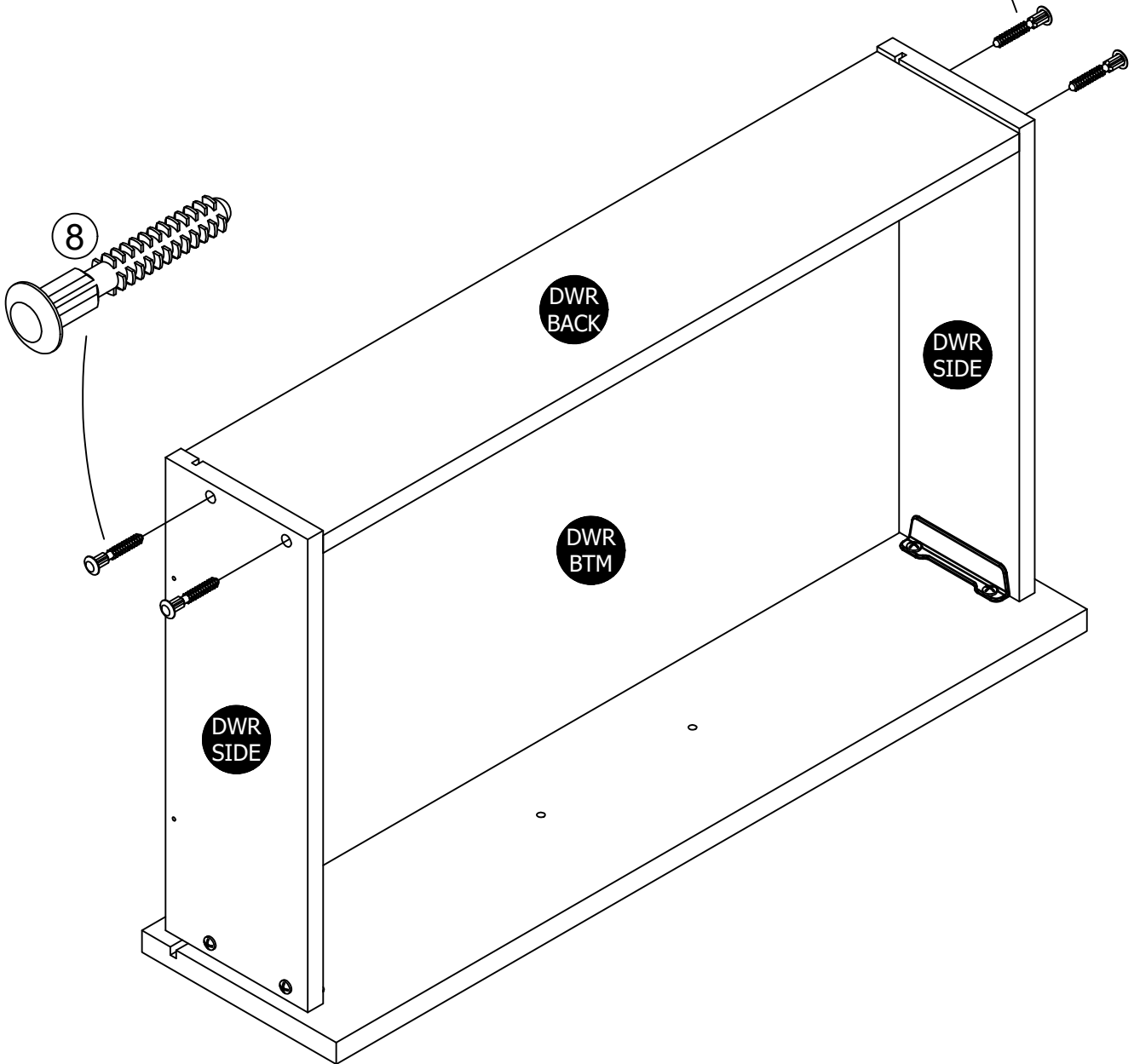
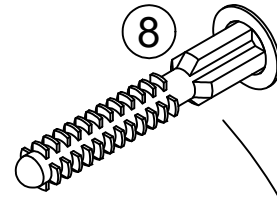
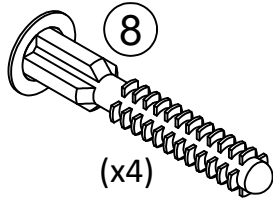
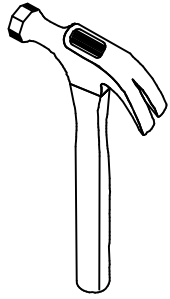

STEP 17

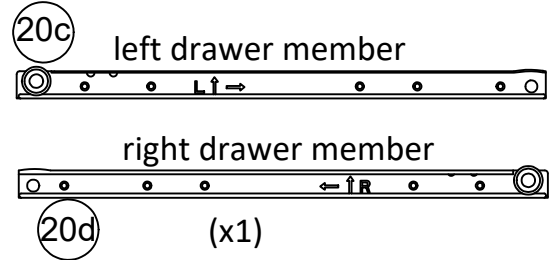
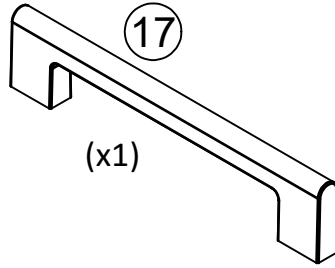
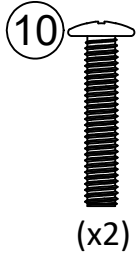
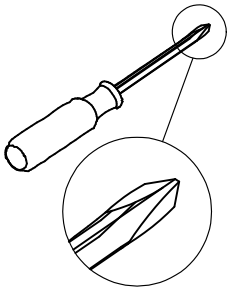

Attach the slides first and then the handle.

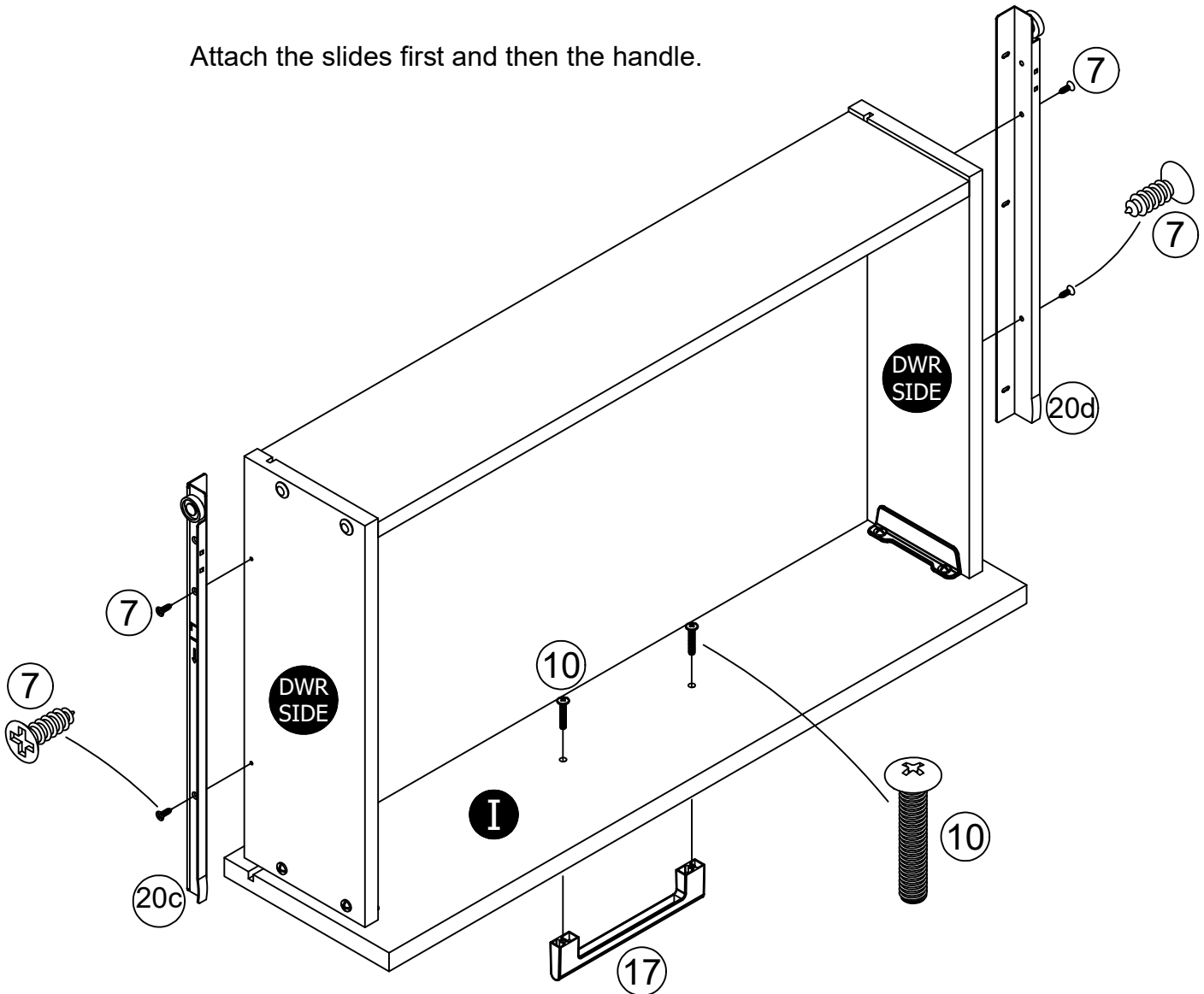

STEP 18

Note: The drawer bracket holes are slotted. Drawer fronts can be adjusted by loosening screws, making needed adjustments and retightening screws.

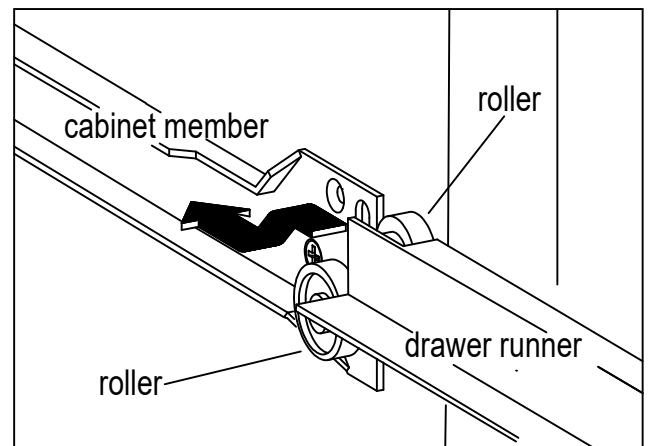
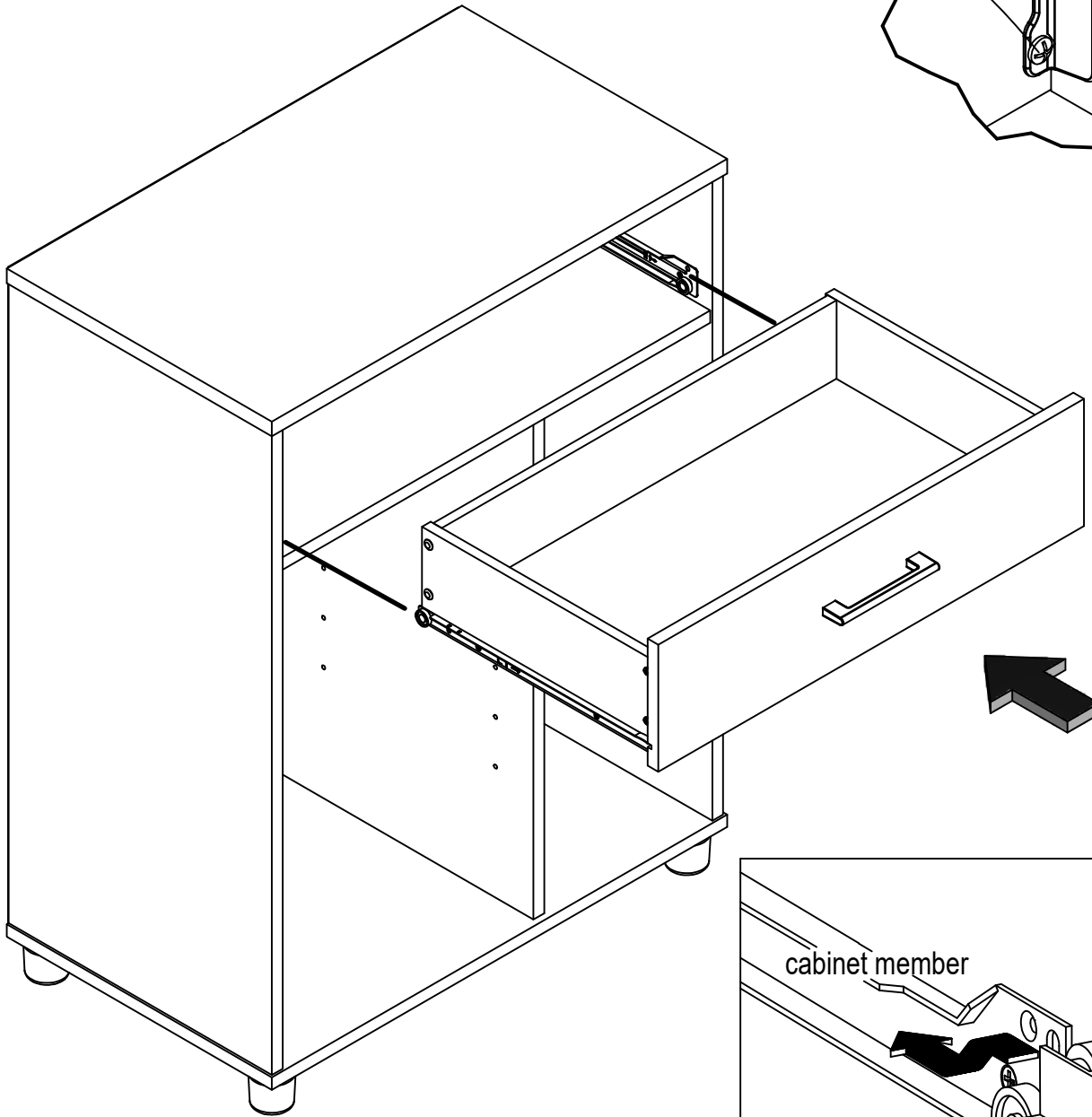
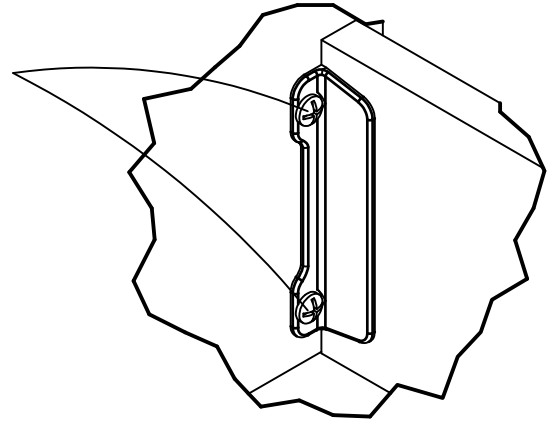

STEP 19

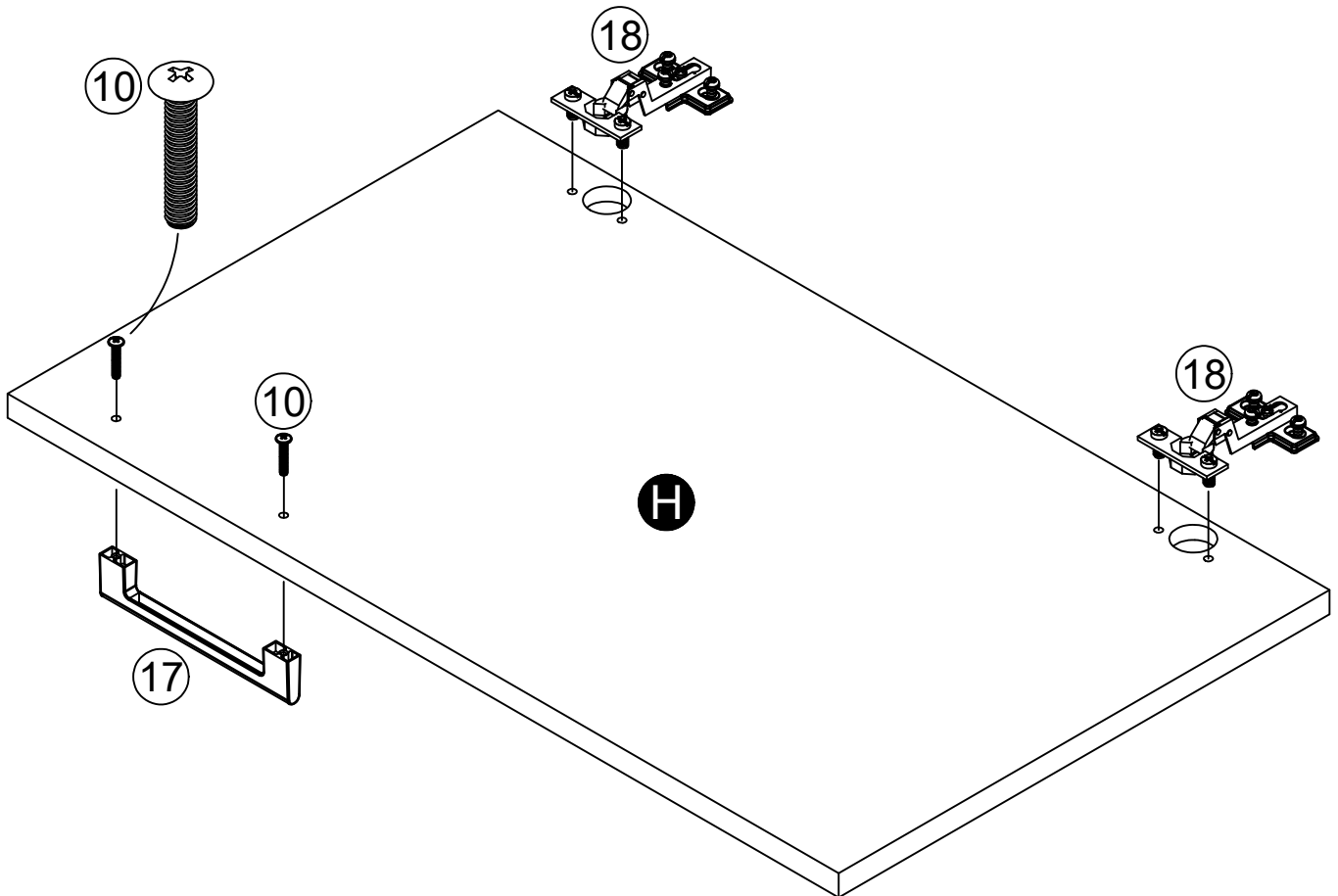
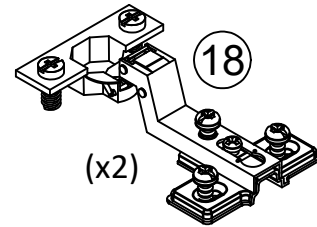
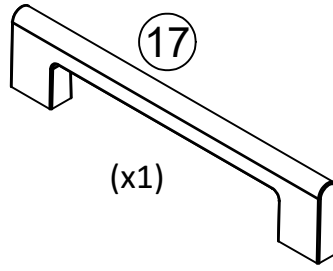
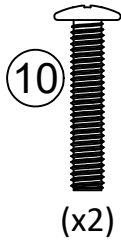
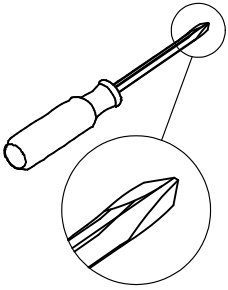

STEP 20

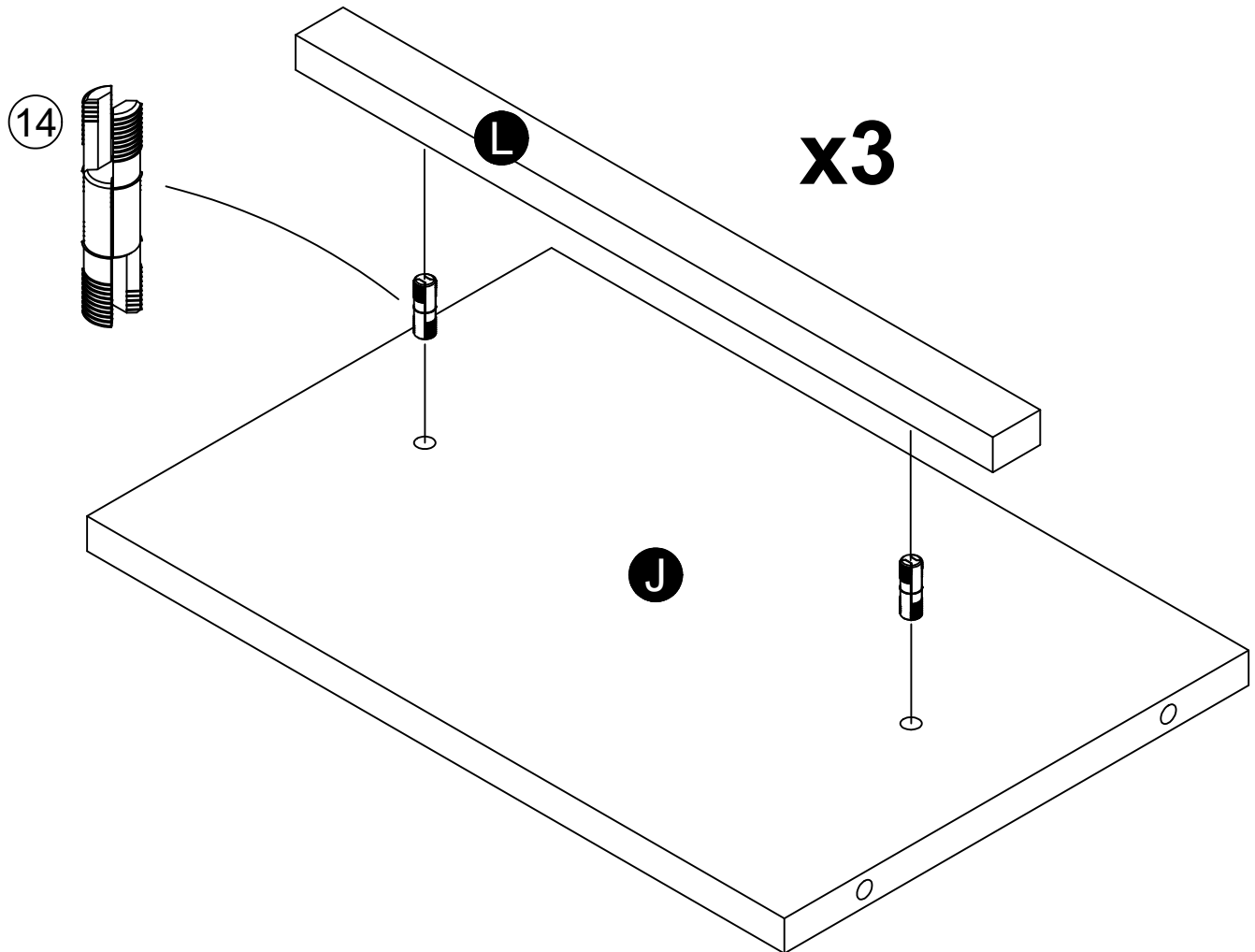
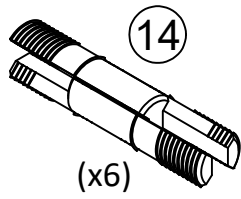

STEP 21

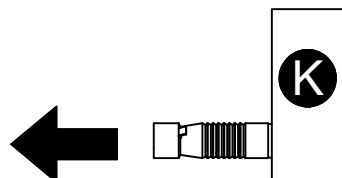
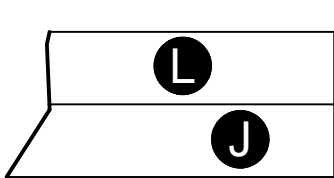
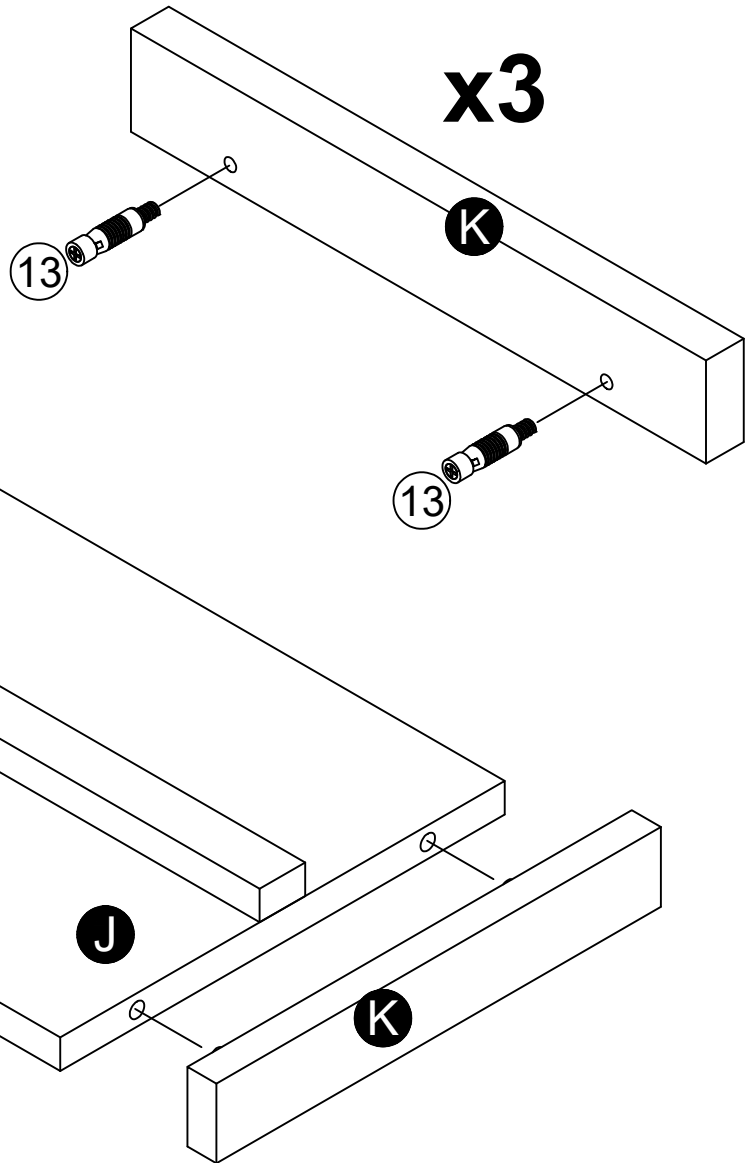
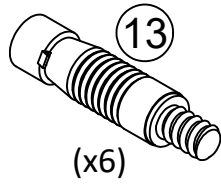
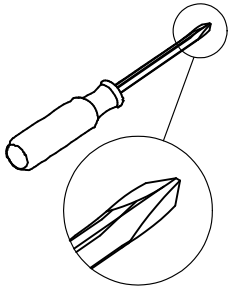

STEP 22

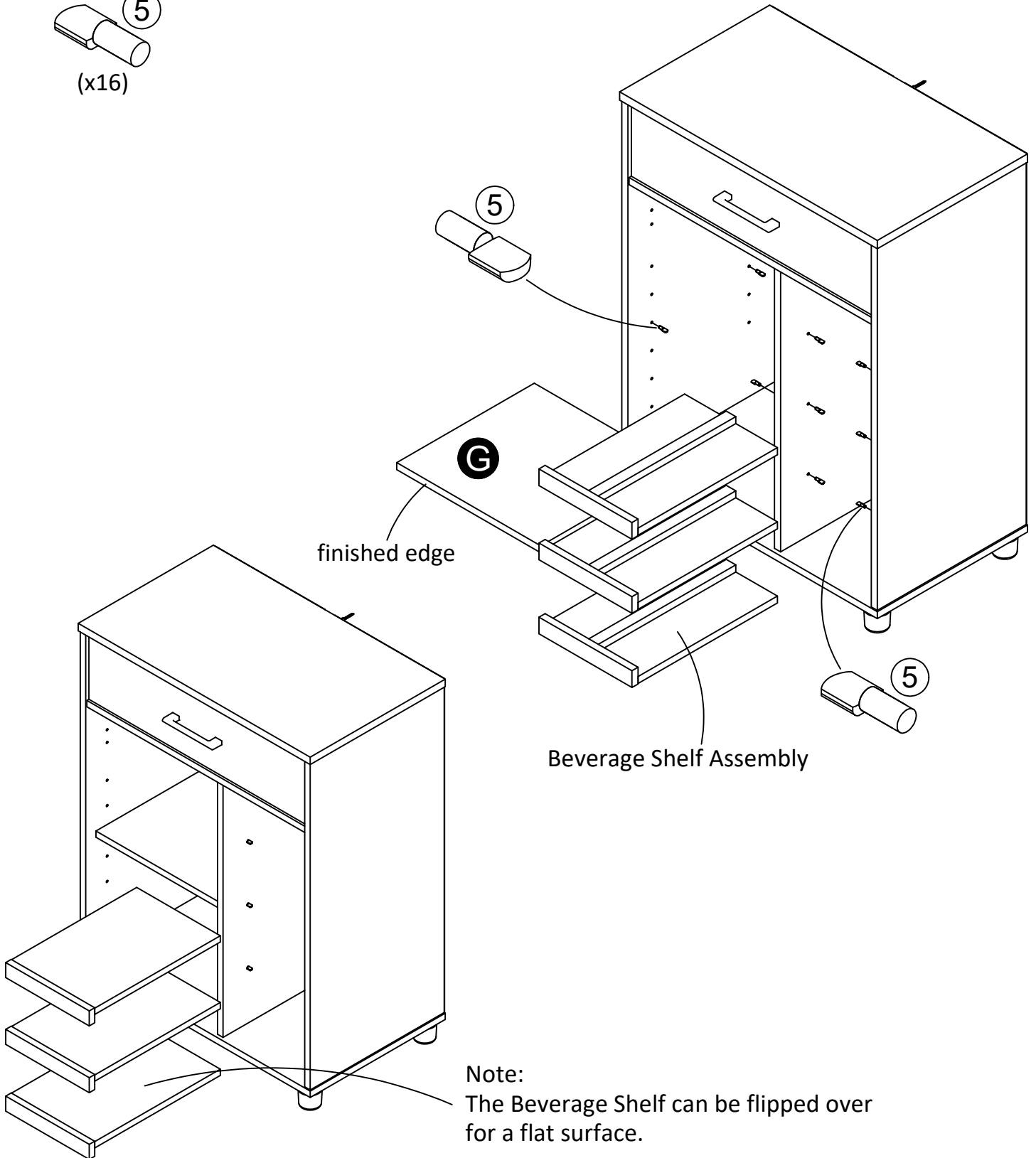
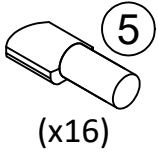

STEP 23

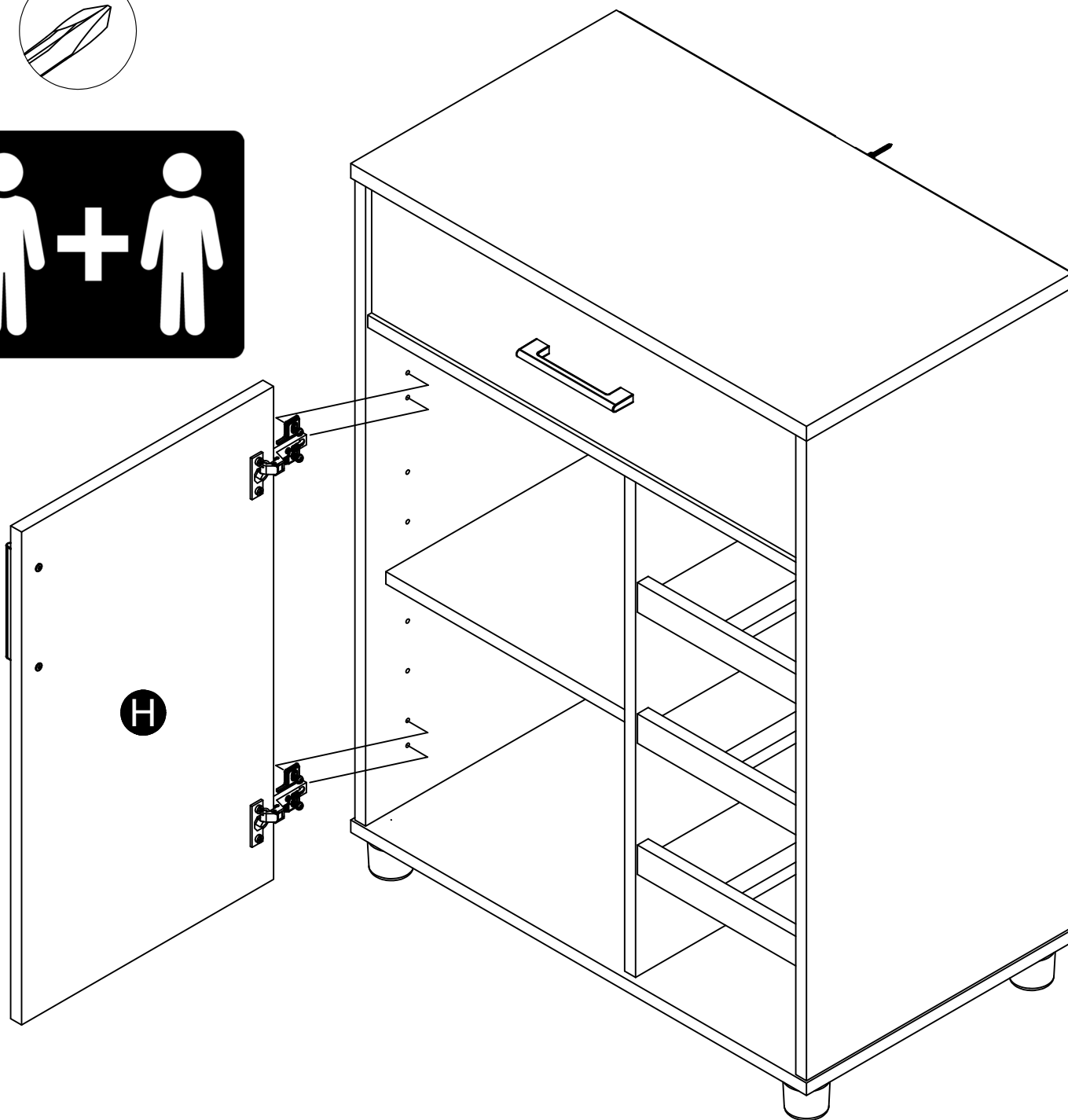
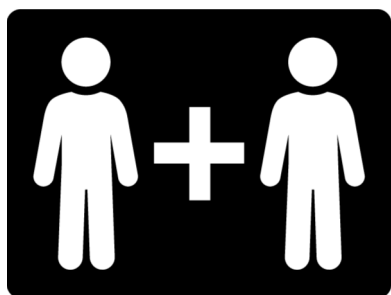
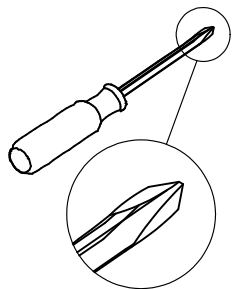

STEP 24

Door Adjustment

To adjust the vertical height:

Loosen the screws "A" on both hinges. They are usually in slotted holes which allows you to adjust up or down by a few mm. Then tighten back up.

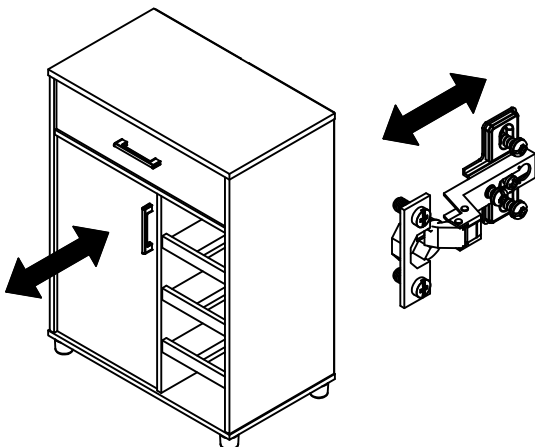
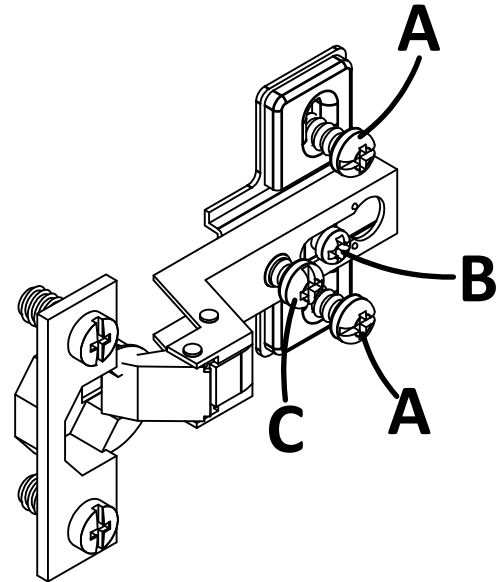
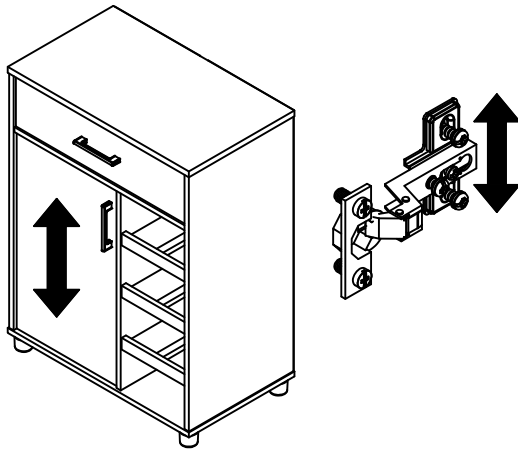

To adjust the depth:

Loosen the screw "B" and adjust door.

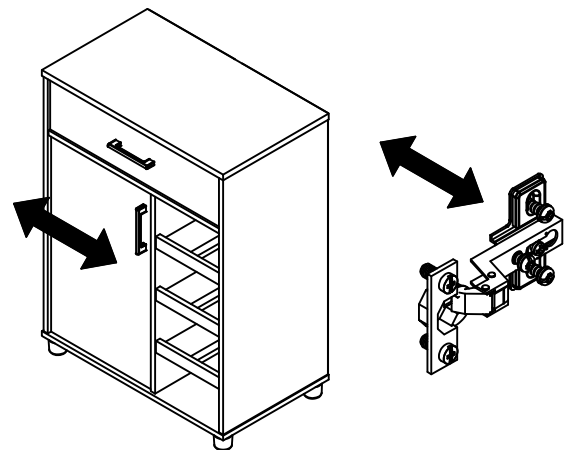

To adjust side to side:

Loosen the screw "C" on BOTH hinges and tighten "B" moves door outward. Loosen "B" and tighten "C" moves doors inward.

Maximum Loads

This unit has been designed to support the maximum loads shown. Exceeding these load limits could cause sagging, instability, product collapse, and/or serious injury.

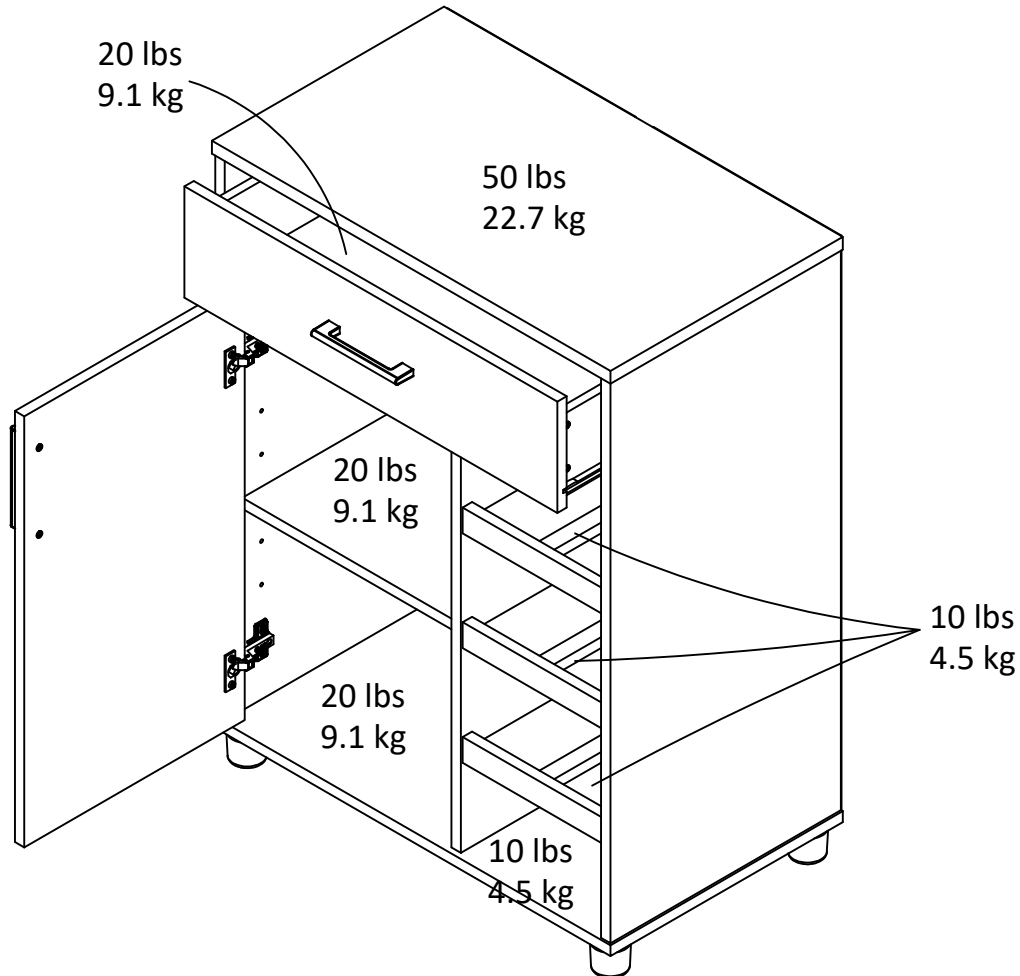

Warning: Risk of injury to persons - do not place a television on this furniture. This furniture is not approved for use with a television.

Certificate of Conformity

1. This certificate applies to the Dorel Home Furnishings, Inc. product identified by this instruction manual.
2. This certificate applies to compliance of this product with the CPSC Ban on Lead-Containing Paint (16 CFR 1303).
3. This product is distributed by: Dorel Home Furnishings, Inc.
410 East First Street South
Wright City, MO 63390
636-745-3351
4. Site of Manufacture: Tiffin OH
5. See front page of instruction manual for date of manufacture.

Register your product to receive the following:



- * New trend details - sneak peek on what's new
- * Surveys - have a voice within our community
- * Exclusive deals and discount codes
- * Quick and easy replacement part service

To register your product, visit systembuild.com

5 Star Rating



Visit your local retailer's website, rate your purchased product and leave us some feedback!

We would like to extend a big "Thank You" to all of our customers for taking the time to assemble this Systembuild product, and to give us your valuable feedback.

*Thank
You!*

Cubierta Delantera

Este libro de instrucciones contiene información **IMPORTANTE** de seguridad. Por favor lea y manténgalo para referencia en el futuro.

No Regrese este producto! Comuníquese con nuestro amistoso equipo de servicio al cliente para obtener ayuda.

Llámenos al: 1-866-452-4081 (Gratis) Lunes - Viernes 9am - 5pm CST

Visitar: www.systembuild.com

PRECAUCION

Este mueble puede volcarse y causar graves heridas y/o muerte.

Anclar el mueble a un poste de madera en la pared (si esto se requiere).

No Permita que los niños monten el mueble.

Mantenga los artículos más pesados en los cajones de abajo.

Consejos Útiles (página 2)

- Abra su artículo en el área donde usted planea utilizarlo para evitar levantar y moverlo menos
- Identificar, ordenar y contar las piezas antes de intentar ensamblar
- Las clavijas de compresión se golpean con un martillo
- Las diapositivas están marcadas con una R (derecha) y L (izquierda) para la colocación correcta
- Asegúrese de que siempre este el punto localizado en la parte superior de bloqueador de leva este volteado hacia borde exterior
- Utilizar todos los clavos para el panel de atrás y distribuirlos por igual
- El panel de atrás debe utilizarse para asegurarse de que la unidad quede fija y firme
- No use químicas fuertes ni limpiadores abrasivos en este artículo
- Nunca empuje, tire ni arrastre los muebles

Antes de Que Empieces (página 3)

- Lea cuidadosamente cada paso y siga el orden correcto
- Separar y contar todas sus piezas y hardware
- Dése suficiente espacio para el proceso de ensamble
- Tenga las siguientes herramientas: destornillador de cabeza plana, #2 cabeza Phillips Destornillador y martillo
- Precaución: Si usa un taladro electrónico o un destornillador eléctrico para atornillar, por favor asegúrese que deje de atornillar cuando el tornillo este apretado. Fallar hacer esto puede causar barrer el tornillo.

Sistema de fijar el bloqueo de leva (página 3)

Esta sistema de fijar el bloqueo de leva sera usado en todo el proceso ensamble.

Página 16

Puede que tenga que martillar ligeramente para que se asiente completamente.

Página 17

No apriete el tornillo por completo.

Página 19

¡IMPORTANTE! EL PANEL TRASERO ES UNA PARTE ESTRUCTURAL DE ESTA UNIDAD Y SE DEBE INSTALAR DE MANERA APROPIADA.

Voltee el gabinete cuidadosamente sobre su lado frontal.

Posicione el panel trasero como se muestra. Alinee de forma recta con los bordes exteriores. Ponga el borde inferior del panel trasero al ras con el borde inferior del fondo y clávelo de forma recta dentro de los bordes posteriores de los paneles izquierdo, derecho, superior e inferior.

Asegúrese de que la unidad esté bien cuadrada.

La distancia de esquina a esquina debe ser igual a la mostrada.

Ponga el borde inferior del Panel Trasero Inferior al ras con el borde inferior del Fondo (D).

Página 20

Para cemento, concreto u otros materiales de la pared:

Consulte con su ferretería local sobre los anclajes apropiados para fijar de manera firme el soporte de seguridad.

¡IMPORTANTE: ESTA UNIDAD SE DEBE ASEGURAR A LA PARED PARA PREVENIR VOLCAMIENTOS. SIGA ESTAS INSTRUCCIONES PARA INSTALAR EL SOPORTE DE SEGURIDAD ANTIVOLCAMIENTO SUMINISTRADO CON ESTE PRODUCTO.

ADVERTENCIA

Si este mueble se voltea puede provocar lesiones graves o fatales.

Para prevenir volcamientos:

- * Instale el dispositivo de sujeción suministrado
- * Coloque los artículos más pesados en las gavetas más bajas
- * A menos que esté específicamente diseñado para tal fin, no coloque televisores ni otros objetos pesados encima de este producto
- * Nunca permita que los niños se suban al mismo, ni que cuelguen de sus gavetas, puertas o repisas
- * Nunca abra más de una gaveta a la vez

El uso de los dispositivos de sujeción podría solamente reducir, más no eliminar por completo el riesgo de volcamientos

OPCIÓN 1: Fijación al entramado (método preferido)

Mediante un buscador de entramado, localice una viga montante en la pared. Coloque su unidad contra la pared, con el soporte de seguridad alineado en dicha ubicación. Para facilitar el atornillado, podría perforar un agujero piloto de 1/8" (3 mm) a través del soporte de seguridad y dentro del entramado. Introduzca el tornillo a través del soporte de seguridad y dentro del entramado. Apriete el tornillo que se quedó sin ser completamente apretado en el paso 9.

OPCIÓN 2: Fijación a paneles de yeso

Ubique su unidad contra la pared que desee y marque dicha pared a través del soporte de seguridad, luego hágala a un lado. Perfore un agujero de 3/16" (5 mm) a través del panel de yeso de la pared. Martille suavemente el anclaje de pared dentro del agujero hasta que quede al ras. Ponga su unidad de vuelta en su lugar y asegure el soporte de pared al anclaje con el tornillo.

Apriete el tornillo que se quedó sin ser completamente apretado en el paso 9.

Página 25

Fije los rieles primero y luego la manilla.

Página 26

Nota: Los agujeros del soporte de la gaveta son ranurados. Los frontales de las gavetas se pueden ajustar aflojando los tornillos, realizando los ajustes necesarios y volviendo a apretar los tornillos.

Página 30

Nota:

La Repisa de Bebidas se puede voltear para tener una superficie plana.

Página 32

Ajuste de la Puerta

Para ajustar la altura vertical:

Afloje los tornillos "A" en ambas bisagras. Estos están usualmente en agujeros ranurados que le permiten ajustarlos hacia arriba o hacia abajo unos pocos milímetros. Luego vuelva a apretarlos.

Para ajustar la profundidad:

Afloje el tornillo "B" y ajuste la puerta.

Para ajustar de lado a lado:

Afloje el tornillo "C" en AMBAS bisagras y apriete el tornillo "B" para mover la puerta hacia afuera. Afloje el tornillo "B" y apriete el tornillo "C" para mover la puerta hacia dentro.

Página 33

CARGA MAXIMA

Esta unidad ha sido diseñada para soportar la carga máxima anotada. El exceder estos límites puede causar inestabilidad, colapsarse y/o causar serias lesiones.

ADVERTENCIA: Riesgo de lesiones a las personas - no coloque un televisor sobre muebles. Este mueble no está aprobado para su uso con un televisor.

Página 34

Registre su producto para recibir lo siguiente:

- * Detalles de nuevas tendencias - Vistazo a lo nuevo
- * Encuestas - aloc su voz entre su comunidad
- * Códigos de ofertas y descuentos exclusivos
- * Fácil y rápido servicio de partes de remplace

Para registrar su producto, visite systembuild.com

Clasificación de 5 estrellas

Visite el sitio web de su tienda local, califique su comprado y denos sus comentarios!

Nos gustaría enviar un gran "Agradecimiento" a todos nuestros clientes por tomarse el tiempo de ensamblar este producto de Systembuild, y por darnos sus valiosos comentarios.

Gracias

Couverture Avant

CE LIVRET D'INSTRUCTION CONTIENT DES INFORMATIONS **IMPORTANTES** SUR LA SÉCURITÉ. VEUILLEZ LIRE ET GARDER POUR UNE RÉFÉRENCE FUTURE

Ne retournez pas ce produit! Contactez notre équipe de service à la clientèle amicale d'abord pour obtenir de l'aide.

Appelez-nous: 1-866-452-4081 (sans frais) du Lundi au Vendredi de 9h à 17h Heure Centrale

Visitez: www.systembuild.com

ATTENTION

Le meuble peut basculer et causer des blessures graves ou la mort.

Ancrer le meuble à une planche murale dans le mur (si indiqué).

Ne laissez pas les enfants grimper sur le meuble.

Placez les articles lourds sur les étagères ou dans les tiroirs inférieurs.

Astuces Utiles (page 2)

- Ouvrez votre article dans la zone que vous prévoyez de le garder pour moins de levage lourd
- Identifier, trier et compter les pièces avant d'essayer d'assembler
- Les goujons de compression sont taraudés avec un Marteau
- Les glissières sont marquées d'un R (droit) et d'un L (gauche) pour un bon placement
- Assurez-vous toujours de faire face la pointe situé sur le haut de la Serrure de Came vers le bord extérieur
- Utiliser tous les clous fournis pour le panneau arrière et les répartir également
- Le panneau arrière doit être utilisé pour vous assurer que votre appareil est robuste
- N'utilisez pas de produits chimiques agressifs ou de nettoyeurs abrasifs sur cet appareil
- Ne jamais pousser, tirer, ou faire glisser votre meuble

Avant de Commencer (page 3)

- Lisez attentivement chaque étape et suivez le bon ordre
- Séparez et comptez toutes vos pièces et matériaux
- Donnez-vous suffisamment de place pour l'assemblage
- Avoir les outils suivants: tournevis à tête plate, #2 tournevis Phillips, et Marteau
- Attention: Si vous utilisez une perceuse électrique ou un tournevis électrique pour visser, veillez à ralentir et arrêter lorsque la vis est bien serrée. Le non-respect de cette consigne peut endommager la vis.

Système de Fixation de Came (page 3)

Ce Système de Fixation de Came sera utilisé tout au long de l'assemblage

Page 16

Vous devrez peut-être taper légèrement avec un marteau afin de vous mettre complètement en place.

Page 17

Ne pas complètement serrer la vis.

Page 19

IMPORTANT! LE PANNEAU ARRIÈRE EST UNE PARTIE STRUCTURELLE DE CETTE UNITÉ ET IL DOIT ÊTRE INSTALLÉ CORRECTEMENT.

Retournez soigneusement l'armoire sur sa face avant.

Positionnez le panneau arrière comme indiqué. Alignez bien les bords extérieurs. Affleurez le bord inférieur du panneau arrière avec le bord inférieur du fond et clouez directement dans les bords arrière du panneau gauche, du panneau droit, du haut et du bas.

Assurez-vous que l'unité est bien à l'équerre.

La distance d'un coin à l'autre doit être égale comme indiqué.

Faites coïncider le bord inférieur du panneau arrière inférieur avec le bord inférieur du fond (D).

Page 20

Pour la maçonnerie, le béton ou d'autres matériaux pour les murs :

Consultez votre quincaillerie locale pour obtenir les ancrages appropriés afin de fixer solidement le support de sécurité.

IMPORTANT : CETTE UNITÉ DOIT ÊTRE FIXÉE AU MUR POUR ÉVITER LE BASCULEMENT. SUIVEZ LES INSTRUCTIONS SUIVANTES POUR INSTALLER LE SUPPORT DE SÉCURITÉ ANTI-RENVERSEMENT FOURNI AVEC CE PRODUIT.

ATTENTION

Le renversement des meubles peut provoquer des blessures graves ou mortelles par écrasement.

Pour prévenir le renversement :

- * Installer un dispositif de retenue en cas de renversement
- * Placer les articles les plus lourds dans les tiroirs les plus bas
- * Sauf s'ils sont spécifiquement conçus pour s'adapter, ne placez pas de téléviseurs ou d'autres objets lourds sur le dessus de cet article
- * Ne jamais laisser les enfants grimper ou se suspendre aux tiroirs, à la porte ou aux étagères
- * Ne jamais ouvrir plus d'un tiroir à la fois

L'utilisation de dispositifs de retenue peut seulement réduire, mais pas éliminer, le risque de renversement

OPTION 1 : Fixation dans un poteau mural (méthode privilégiée)

À l'aide d'un chercheur de goujons, localisez un goujon dans le mur. Placez votre appareil contre le mur, avec le support de sécurité aligné à cet endroit. Pour faciliter le vissage, vous pouvez percer un trou pilote de 3 mm de diamètre dans le goujon, à travers le support de sécurité. Enfoncez la vis dans le montant mural en passant par le support de sécurité. Serrez la vis qui n'a pas été complètement serrée à l'étape 9.

OPTION 2 : Fixation dans les cloisons sèches

Placez votre unité à l'endroit souhaité contre un mur et marquez celui-ci à travers le support de sécurité, puis déplacez ensuite votre unité sur le côté. Percez un trou de 5 mm de diamètre dans le panneau mural. Tapez l'ancrage mural dans le trou jusqu'à ce qu'il soit à fleur. Mettez votre appareil en place et fixez le support mural à l'ancrage mural avec la vis. Serrez la vis qui n'a pas été complètement serrée à l'étape 9.

Page 25

Fixez d'abord les glissières, puis la poignée.

Page 26

Note : Les trous des supports de tiroir sont fendus. Les façades des tiroirs peuvent être ajustées en desserrant les vis, en effectuant les réglages nécessaires et en les resserrant.

Page 30

Note :

L'étagère à boissons peut être renversée pour obtenir une surface plane.

Page 32

Ajustement de la porte

Pour régler la hauteur verticale :

Desserrer les vis « A » des deux charnières. Elles se trouvent généralement dans des trous oblongs, ce qui vous permet de les ajuster de quelques millimètres vers le haut ou vers le bas. Puis resserrez-les.

Pour régler la profondeur :

Desserrer la vis « B » et ajuster la porte.

Pour s'ajuster d'un côté à l'autre :

Desserrer la vis « C » sur les DEUX charnières et serrer « B » déplace la porte vers l'extérieur. Desserrer la vis « B » et serrer la vis « C » déplace la porte vers l'intérieur.

Page 33

CHARGES MAXIMALES

Ce meuble a été conçu pour supporter les charges maximales indiquées. En excédant ces limites de charge, le meuble pourrait devenir instable, s'effondrer, et/ou causer des blessures graves.

AVERTISSEMENT : Risque de blessure corporelle - ne pas placer une télévision sur ce meuble. Ce meuble n'est pas approuvé pour une utilisation avec une télévision.

Page 34

Enregistrez votre produit pour recevoir les éléments suivantes:

- * Détails sur les nouvelles tendances - un aperçu sur les nouveautés
- * Sondages - avoir une voix au sein de notre communauté
- * Offres exclusives et codes promo
- * Service de pièces de rechange rapide et facile

Pour enregistrer votre produit, visitez systembuild.com

5 Étoiles

Visitez le site Web de votre détaillant local, évaluez votre produit acheté et laissez-nous quelques commentaires !

Nous tenons à offrir un grand "Merci" à tous nos clients pour avoir pris le temps d'assembler ce produit "Systembuild", et de nous donner vos commentaires précieux.

Merci